

EXPLICIT HORIZONTAL OPEN BOOKS ON SOME PLUMBINGS

TOLGA ETGÜ AND BURAK OZBAGCI

ABSTRACT. We describe explicit open books on arbitrary plumbings of oriented circle bundles over closed oriented surfaces. We show that, for a non-positive plumbing, the open book we construct is horizontal and the corresponding compatible contact structure is also horizontal and Stein fillable. In particular, we describe horizontal open books on some Seifert fibered 3-manifolds. As another application we describe horizontal open books isomorphic to Milnor open books for some complex surface singularities. Moreover we give examples of tight contact 3-manifolds supported by planar open books. As a consequence the Weinstein conjecture holds for these tight contact structures [ACH].

1. INTRODUCTION

In this article using 3-dimensional simple surgery techniques we first construct explicit open books on oriented circle bundles over closed oriented surfaces. Then we construct open books on plumbings of circle bundles according to a graph by appropriately gluing the open books we constructed for the circle bundles involved in the plumbing. (We will use the word graph for a connected graph with at least two vertices.) An open book on a circle bundle or more generally on a plumbing of circle bundles is called *horizontal* if its binding is a collection of some fibers and its pages are transverse to the fibers. Here we require that the orientation induced on the binding by the pages coincides with the orientation of the fibers induced by the fibration.

We will call a plumbing graph *non-positive* if the sum of the degree of the vertex and the Euler number of the bundle corresponding to that vertex is non-positive for every vertex of the graph. We prove that the open book we construct on a circle bundle with negative Euler number or on a non-positive plumbing of circle bundles is horizontal. It turns out that the contact structure compatible with this open book is also *horizontal*, i.e. the contact planes (possibly after an isotopy of the contact structure) are transverse to the fibers. Furthermore we show that the monodromy of this horizontal open book is given by a product of right-handed Dehn twists along disjoint curves. Consequently, by a theorem of Giroux [Gi], our horizontal open book is compatible with a Stein fillable contact structure. Recall that

Date: May 4, 2011.

2000 *Mathematics Subject Classification.* 57R17, 53D10, 32S55, 32S25 .

T.E. was partially supported by the Turkish Academy of Sciences; B.O. was partially supported by the Turkish Academy of Sciences and by the NSF Focused Research Grant FRG-024466.

Eliashberg and Gromov [EG] proved that every fillable contact structure is tight. As a first application of our construction we describe explicit horizontal open books on some Seifert fibered 3–manifolds.

A contact 3–manifold (Y, ξ) is said to be *Milnor fillable* if it is contactomorphic to the contact boundary of an isolated complex surface singularity (X, x) . The germ (X, x) is called a *Milnor filling* of (Y, ξ) . An analytic function $f : (X, x) \rightarrow (\mathbb{C}, 0)$ with an isolated singularity at x defines an open book decomposition of Y which is called a *Milnor open book*. It was shown in [CNP] that any Milnor open book of a Milnor fillable contact 3–manifold (Y, ξ) is horizontal and compatible with the contact structure ξ . We would like to point out that a Milnor fillable contact structure is Stein fillable and hence tight.

A Milnor fillable contact 3–manifold is obtained as a plumbing of some circle bundles over surfaces which is topologically completely determined by the minimal good resolution of the singularity. As a second application we describe explicit open books isomorphic to Milnor open books for some complex surface singularities.

On the other hand, in [Ga], using 4–dimensional symplectic handle attachments, Gay gives a construction of open books on plumbings of circle bundles. It turns out that the open book we construct on a given plumbing is isomorphic to Gay’s open book, showing in particular that the open book in his construction can be made horizontal for non-positive plumbings. If a plumbing graph is not non-positive, then there are binding components in our open book which are oriented opposite to the fiber orientation, and hence the open book fails to be horizontal.

Finally we give examples of planar open books whose compatible contact structures are Stein fillable and hence tight. As a consequence the Weinstein conjecture holds for these tight contact structures, since the conjecture is proved for every contact structure compatible with a planar open book (cf. [ACH]). Planar open books compatible with some Stein fillable contact structures were also constructed independently by Schönenberger in his thesis [Sc], using completely different techniques.

Acknowledgement: We are grateful to John Etnyre and András Stipsicz for their critical comments on the first draft of this paper that helped us to improve our earlier results. We would also like to thank Mohan Bhupal, Ferit Öztürk, and Meral Tosun for helpful conversations.

2. OPEN BOOK DECOMPOSITIONS AND CONTACT STRUCTURES

We will assume throughout this paper that a contact structure $\xi = \ker \alpha$ is coorientable (i.e., α is a global 1–form) and positive (i.e., $\alpha \wedge d\alpha > 0$). In the following we describe the compatibility of an open book decomposition with a given contact structure on a 3–manifold.

Suppose that for an oriented link L in a 3-manifold Y the complement $Y \setminus L$ fibers over the circle as $\pi: Y \setminus L \rightarrow S^1$ such that $\pi^{-1}(\theta) = \Sigma_\theta$ is the interior of a compact surface bounding L , for all $\theta \in S^1$. Then (L, π) is called an *open book decomposition* (or just an *open book*) of Y . For each $\theta \in S^1$, the surface Σ_θ is called a *page*, while L the *binding* of the open book. The monodromy of the fibration π is defined as the diffeomorphism of a fixed page which is given by the first return map of a flow that is transverse to the pages and meridional near the binding. The isotopy class of this diffeomorphism is independent of the chosen flow and we will refer to that as the *monodromy* of the open book decomposition.

An open book (L, π) on a 3-manifold Y is said to be *isomorphic* to an open book (L', π') on a 3-manifold Y' , if there is a diffeomorphism $f: (Y, L) \rightarrow (Y', L')$ such that $\pi' \circ f = \pi$ on $Y \setminus L$. In other words, an isomorphism of open books takes binding to binding and pages to pages.

Theorem 1 (Alexander [Al]). *Every closed and oriented 3-manifold admits an open book decomposition.*

In fact, every closed oriented 3-manifold admits a planar open book, which means that a page is a disk D^2 with holes [R]. On the other hand, every closed oriented 3-manifold admits a contact structure [M]. So it seems natural to strengthen the contact condition $\alpha \wedge d\alpha > 0$ in the presence of an open book decomposition on Y by requiring that $\alpha > 0$ on the binding and $d\alpha > 0$ on the pages.

Definition 2. *An open book decomposition of a 3-manifold Y and a contact structure ξ on Y are called compatible if ξ can be represented by a contact form α such that the binding is a transverse link, $d\alpha$ is a symplectic form on every page and the orientation of the transverse binding induced by α agrees with the boundary orientation of the pages.*

Theorem 3 (Giroux [Gi]). *Every contact 3-manifold admits a compatible open book. Moreover two contact structures carried by the same open book are isotopic.*

In particular, in order to show that two contact structures on a given 3-manifold are contactomorphic, it suffices to show that they are carried by isomorphic open books. We refer the reader to [Et2] and [OS] for more on the correspondence between open books and contact structures.

3. EXPLICIT CONSTRUCTION OF OPEN BOOKS

We will assume throughout the paper that the circle bundles we consider are oriented and the base space is a closed oriented surface. An open book on a single circle bundle or on a plumbing of circle bundles (according to a graph) is called *horizontal* if its binding is a collection of some fibers in the circle bundles, its pages are transverse to the fibers of the circle bundles and the orientation induced on the binding by the pages coincides with the orientation of the fibers induced by the fibration.

We start with constructing an open book on a circle bundle with negative Euler number. We show that our construction yields a horizontal open book, whose compatible contact structure is horizontal as well. Then we generalize the construction to circle bundles with non-negative Euler numbers, but the open books we construct on those bundles are not horizontal.

3.1. Construction of an open book on an oriented circle bundle over an oriented surface. Let Σ denote a closed oriented surface and let M denote the trivial circle bundle over Σ , i.e., $M = S^1 \times \Sigma$. We pick a circle fiber K of M and perform $+1$ -surgery along K . The resulting 3-manifold M' is a circle bundle over Σ whose Euler number is equal to -1 . This can be verified using Kirby calculus (cf. [GS]), for example, as shown in Figure 1.

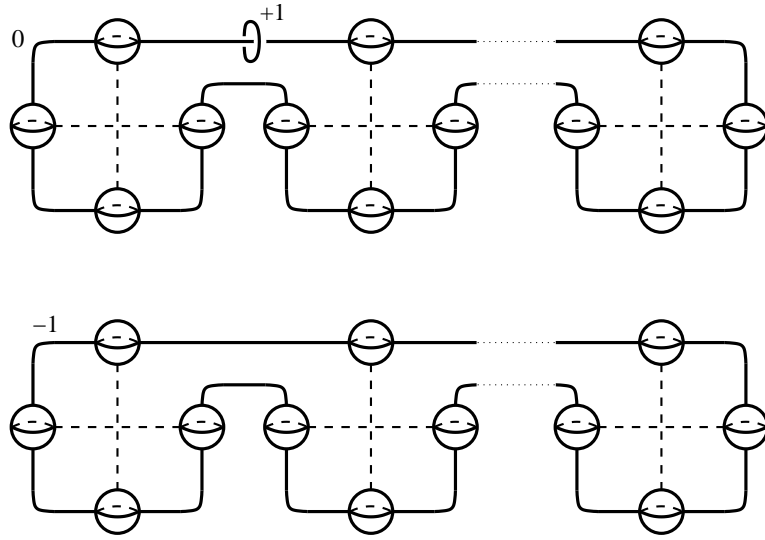

FIGURE 1. The diagram on top shows $D^2 \times \Sigma$ (whose boundary is $S^1 \times \Sigma$) along with a $+1$ -surgery curve transverse to Σ . One can visualize the surface Σ as the disk (bounded by the 0-framed knot) union 2-dimensional 1-handles going over the 4-dimensional 1-handles. We blow down the $+1$ curve to get a disk bundle over Σ with Euler number -1 . The boundary of this disk bundle at the bottom is a circle bundle over Σ with Euler number -1 .

In order to describe an open book on M' we first consider the affect of removing a solid torus neighborhood $N = K \times D^2$ of K from M . By removing N from M we puncture once each Σ in $M = S^1 \times \Sigma$ to get $S^1 \times \tilde{\Sigma}$, where $\tilde{\Sigma} = \Sigma \setminus D^2$. Now we will glue a solid torus back to $S^1 \times \tilde{\Sigma}$ along its boundary torus $S^1 \times \partial\tilde{\Sigma}$ in order to perform our surgery.

Consider the solid torus $S^1 \times D^2$ shown on the left-hand side in Figure 2. Let μ and λ be the meridian and the longitude pair of $S^1 \times \partial D^2$. Let m and l denote the meridian and the longitude pair in the boundary of $S^1 \times \tilde{\Sigma}$. Note that the base surface is oriented (as we depicted in Figure 2) and the orientation induced on $\partial\tilde{\Sigma}$ is the opposite of the orientation of m . We glue the solid torus $S^1 \times D^2$ to $S^1 \times \tilde{\Sigma}$ by an *orientation preserving* diffeomorphism $S^1 \times \partial D^2 \rightarrow S^1 \times \partial\tilde{\Sigma}$ which sends μ to $m + l$ and λ to l . The resulting 3-manifold M' will be oriented extending the orientation on $S^1 \times \tilde{\Sigma}$ induced from M . We use orientation preserving map rather than reversing because of our choice of orientations above.

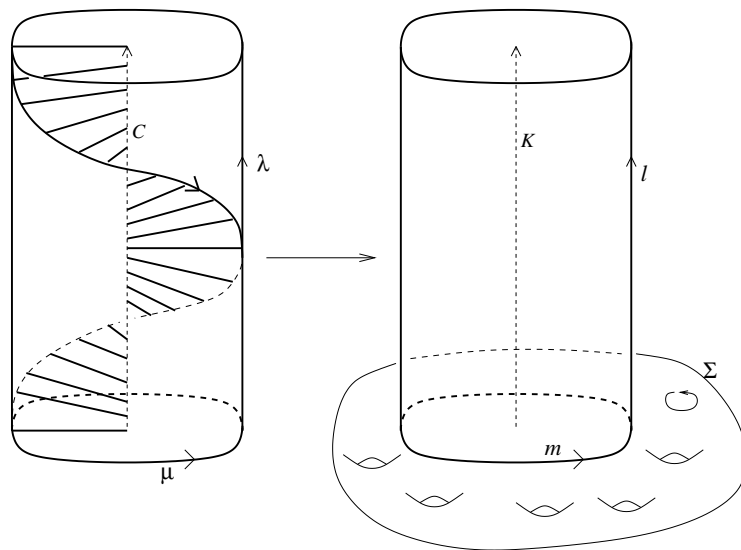

FIGURE 2. The surgery torus is obtained by identifying the top and the bottom of the cylinder shown on the left-hand side. On the right hand side we depict the complement obtained by removing a neighborhood of a circle fiber from $S^1 \times \Sigma$.

In Figure 2, we also depict a leaf (an annulus) of a foliation on the solid torus $S^1 \times D^2$ that we will glue to perform $+1$ -surgery. Note that $S^1 \times D^2$ is a trivial circle bundle over D^2 where the circle fibers are transverse to the annuli foliation. The boundary of a leaf consists of the core circle C of $S^1 \times D^2$ and a $(1, -1)$ -curve on $S^1 \times \partial D^2$, i.e., a curve homologous to $\mu - \lambda$. Each leaf is oriented so that the induced orientation on the boundary of a leaf is given as indicated in Figure 2. The gluing diffeomorphism maps $\mu - \lambda$ onto m so that by performing the $+1$ -surgery we also glue each annulus in the foliation to a $\tilde{\Sigma}$ in $S^1 \times \tilde{\Sigma}$ identifying the outer boundary component (i.e., the $(\mu - \lambda)$ -curve) of the annulus with $\partial\tilde{\Sigma}$. Hence this construction yields an open book on M' whose binding is C (the core

circle of the surgery torus) and pages are obtained by gluing an annulus to each $\tilde{\Sigma}$ along $\partial\tilde{\Sigma}$. Notice that the pages will be oriented extending the orientation on $\tilde{\Sigma}$ induced from Σ . Finally we want to point out that the core circle C becomes an oriented fiber of the circle fibration of M' over Σ .

Next we will describe the monodromy of this open book. In order to measure the monodromy of an open book we should choose a flow which is transverse to the pages and meridional near the binding. Take a *vertical* vector field pointing along the fiber direction in $S^1 \times \tilde{\Sigma}$ and extend it inside the surgery torus (along every ray towards the core circle) by rotating clockwise so that it becomes horizontal near the core circle. Observe that since the vector field is horizontal near the binding, the first return map of the flow generated by this vector field will fix the points near the binding on any leaf. Now take a horizontal arc (on a leaf) connecting the core circle to the other boundary of that leaf. Then one can see that the flow will move the points of this arc further to the right if we move towards the boundary. Note that the first return map will fix the points on $\tilde{\Sigma}$ as well as the points near the binding. Combining this discussion we conclude that the first return map is given by a right-handed Dehn twist along the core circle of the leaf, which is indeed a curve parallel to the boundary of the open book.

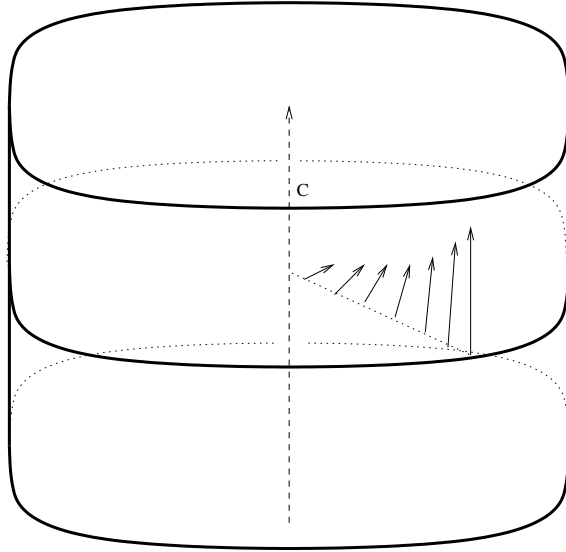

FIGURE 3. The vector field depicted along a ray towards the core circle inside the surgery torus extending the vertical one on $S^1 \times \tilde{\Sigma}$. The vector field becomes horizontal near the core (binding) along any ray.

In summary we constructed a horizontal open book on a circle bundle over a genus g surface Σ with Euler number -1 by performing a $+1$ -surgery on a circle fiber of a trivial circle bundle. It is clear that if we take s disjoint fibers in $S^1 \times \Sigma$ and perform $+1$ -surgery along each of these fibers, we will get a horizontal open book on a circle bundle over Σ with Euler number $e = -s < 0$. The binding of the resulting open book will be the union of s circle fibers and a page will be a genus g surface with s boundary components. The monodromy will be the product of right-handed Dehn twists along boundary components. Consequently the compatible contact structure is Stein fillable (cf. [Gi]). Thus we get

Proposition 4. *There exists an explicit horizontal open book on a circle bundle with negative Euler number which is compatible with a Stein fillable contact structure.*

Next we consider the contact structure compatible with our open book.

Proposition 5. *The contact structure compatible with the open book we constructed on a circle bundle with negative Euler number is horizontal, i.e., the contact planes (possibly after an isotopy of the contact structure) are positively transverse to the fibers.*

Proof. By Lemma 3.5 in [Et2] we may assume that the contact planes are arbitrarily close to the tangents of the pages away from the binding. So clearly the contact planes are positively transverse to the fibers away from the binding since the pages of our open book are already positively transverse to the fibers.

Note that near a component C of the binding we have explicitly constructed the pages, and the fibers of the circle fibration can be viewed as straight vertical lines in the solid cylinder on the left-hand side in Figure 2 before we identify the top and the bottom. On the other hand, by the compatibility condition, there are coordinates $(z, (r, \theta))$ near C , where C is $\{r = 0\}$ and a page is given by setting θ equal to a constant such that the contact structure is given by the kernel of the form $dz + r^2 d\theta$. In these new coordinates the neighborhood of C in Figure 2 is seen as in Figure 4, where the annulus is straightened out and the circle fibers are wrapped once around the cylinder in a right-handed manner. More precisely, the tangent vector to an (oriented) fiber is given by $\partial_\theta + \partial_z$. Hence one can see that the contact planes will remain positively transverse to the circle fibers in a neighborhood of C , since

$$(dz + r^2 d\theta)(\partial_\theta + \partial_z) = r^2 + 1 > 0.$$

□

Remark 6. *In fact, the same argument can be generalized to prove that the contact structure compatible with any horizontal open book on a circle bundle is horizontal. Any horizontal contact structure on a circle bundle is universally tight by Lemma 3.9 in [H]*

Note that the same construction of an open book will work when we perform -1 -surgeries along fibers, but in that case the orientation on the binding induced by the pages

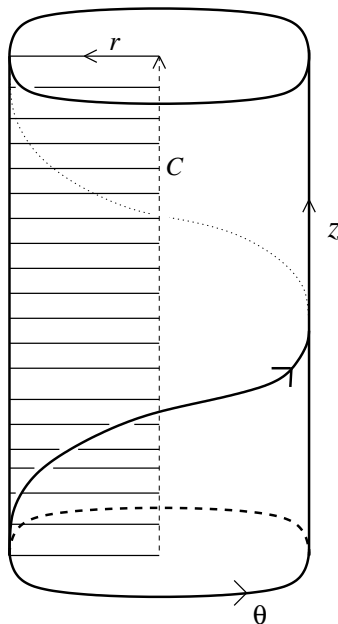

FIGURE 4. A circle fiber is given by a $(1, 1)$ -curve in a neighborhood of a component C of the binding.

will be the opposite of the fiber orientation. Thus the open book we construct using -1 -surgeries will not be horizontal. Moreover we will get left-handed Dehn twists along boundary components instead of right-handed Dehn twists. Nevertheless, by taking s disjoint fibers in $S^1 \times \Sigma$ and performing a -1 -surgery along each of these fibers, we will get an open book on a circle bundle over Σ with Euler number $e = s > 0$.

Finally, to obtain an open book on a circle bundle with zero Euler number we first observe that by performing a $+1$ -surgery on a fiber and a -1 -surgery in another fiber does not change the topology of the 3-manifold which fibers over a surface. Hence by performing a canceling pair of a ± 1 surgeries on distinct fibers, we can construct an open book on a circle bundle with zero Euler number with two binding components, where the monodromy is given by a right-handed Dehn twists along one boundary component and a left-handed Dehn twist along the other.

3.2. Construction of an open book on a plumbing of oriented circle bundles over oriented surfaces. We will construct open books for plumbings of circle bundles. We start with describing an open book on the plumbing of two circle bundles. We obtain our open book by suitably gluing the open books we constructed on the circle bundles in the previous section.

Let M_i denote a circle bundle over a closed surface Σ_i with Euler number e_i for $i = 1, 2$. In the previous section we constructed an open book on M_i . We observed that by performing a $+1$ -surgery on a fiber and a -1 -surgery in another fiber does not change the topology of the 3-manifold which fibers over a surface. Thus we can assume that M_i is obtained from $S^1 \times \Sigma$ by ± 1 -surgeries along (disjoint fibers) such that there are as many fibers as we wish on which we perform $+1$ -surgeries.

Fix one of the circles where we performed a $+1$ -surgery to obtain M_i . Consider the surgery process we described in the previous section. Take a smaller solid torus neighborhood J_i (see Figure 5) of the surgery torus we glued in to perform $+1$ -surgery. To obtain a plumbing of M_1 and M_2 we remove J_i from M_i and identify boundary tori $\partial J_1, \partial J_2$ by an orientation reversing diffeomorphism $\partial J_1 \rightarrow \partial J_2$ taking μ_1 to λ_2 and λ_1 to μ_2 . Here as in the previous section (μ_i, λ_i) denote the meridian and the longitude pair for J_i . Note that this diffeomorphism will take $\mu_1 - \lambda_1$ to $-(\mu_2 - \lambda_2)$.

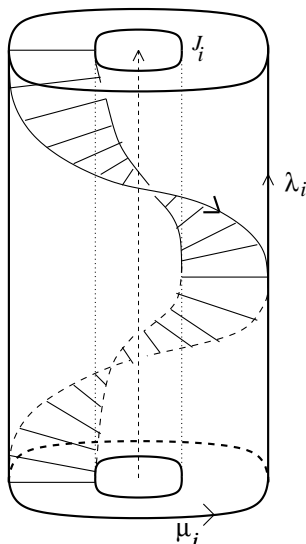

FIGURE 5. Removing a smaller neighborhood of the binding

The point here is that when we remove J_i from M_i we remove a (small) annulus neighborhood of a binding component from every page. The remaining part of the annulus in the pages will intersect the boundary torus ∂J_i as a curve homologous to $\mu_i - \lambda_i$. Hence when we plumb the circle bundles we actually glue the pages (after removing a binding component) of the open books on M_i to obtain an open book on the plumbing. The new page will be obtained from the pages of the open books on M_1 and M_2 by gluing together one boundary component of the open book on M_1 with one boundary component of the open book on M_2 (both of which were induced by $+1$ -surgery). Note that the glued up page

will be oriented extending the orientations of the pages that we glue together. Moreover the pages will be transverse to the fibers by construction.

To calculate the monodromy of the open book on the plumbed manifold we just observe that the flows we used to calculate monodromies of the open books on each piece in the plumbing will also glue together: We can assume that the flow has a constant slope 1 (given by tangents to the curves $\mu_i + \lambda_i$) on each boundary torus so that the gluing map will take one to the other to define a flow on the closed 3-manifold obtained by plumbing. When we glue the two flows, since each flow will have the affect of moving the points on the half annuli (see Figure 5) to the right by 180-degrees we get a right-handed Dehn twist along the annulus obtained by gluing the two half annuli.

Next we describe an explicit open book on arbitrary plumbings of circle bundles according to a weighted graph. Suppose that we are given a plumbing according to a weighted graph with k vertices such that each vertex is decorated with a pair of integers (e_i, g_i) , where e_i is the Euler number and g_i is the genus of the base surface Σ_i of the i^{th} circle bundle M_i in the plumbing. Let d_i denote the degree of the i^{th} vertex.

First assume that $e_i \geq 0$. Then we can view M_i as obtained from $S^1 \times \Sigma_i$ by performing -1 -surgeries on e_i distinct fibers. To be able to plumb M_i to other circle bundles d_i times, we need to use d_i fibers with $+1$ -surgeries. So we apply extra $+1$ -surgeries on d_i fibers as well as -1 -surgeries on some other d_i fibers not to change the topology of M_i . Since we will use all the $+1$ -surgeries in the plumbing process we will end up with $e_i + d_i$ fibers on which we performed -1 -surgeries.

Now assume that $e_i < 0$. Then we can view M_i as obtained from $S^1 \times \Sigma_i$ by performing $+1$ -surgeries on $-e_i$ distinct fibers. If we further assume that $d_i > -e_i$ we perform $d_i + e_i$ extra $+1$ and -1 -surgeries and use all the $+1$ -surgeries for the plumbing to end up with $d_i + e_i$ fibers on which we applied -1 -surgeries. The only remaining case is $d_i \leq -e_i$ when $e_i < 0$. In this case we can use d_i of these $+1$ -surgeries in the plumbing and we will end up with $-e_i - d_i$ fibers on which we applied $+1$ -surgeries.

Combining all the discussion above, a page of the open book on this plumbing will be obtained by gluing together surfaces F_i of genus g_i with $|e_i + d_i|$ boundary components according to the given graph. (Note, however, that we will not use these boundary components in the gluing.) Each edge in the graph will become a 1-handle (a neck) in the page connecting the surfaces corresponding to the vertices connected by that edge. The monodromy of the open book will be given as a product of one boundary-parallel Dehn twist for each boundary component of the page and one right-handed Dehn twist along the cocore circle of each 1-handle coming from an edge. If $e_i + d_i > 0$ ($e_i + d_i < 0$, resp.) for some i , then the boundary parallel Dehn twists in F_i will be left-handed (right-handed, resp.). Here we will assume that *there is at least one vertex in a plumbing graph such that $e_i + d_i$ is non-zero*, to avoid the case of empty binding which we do not want to allow in the definition of an open book. In particular, note that if the plumbing graph is non-positive

then our open book will be horizontal since we do not use any -1 -surgeries in that case. Moreover the compatible contact structure is Stein fillable (cf. [Gi]) since the monodromy of the open book for a non-positive plumbing is a product of right-handed Dehn twists. Hence we get

Theorem 7. *There exists an explicit horizontal open book on a non-positive plumbing of circle bundles over surfaces which is compatible with a Stein fillable contact structure.*

Furthermore we have

Proposition 8. *The contact structure compatible with the open book we constructed on a non-positive plumbing of circle bundles over surfaces is horizontal, i.e., the contact planes (possibly after an isotopy of the contact structure) are positively transverse to the fibers.*

Proof. In Proposition 5, we proved that the contact structure compatible with the open book we constructed on a circle bundle with negative Euler number is horizontal. Recall that the open book on a plumbing of two circle bundles is obtained by removing a neighborhood of a binding component from each open book and gluing along the resulting boundary tori. The result follows, by the same argument used in Proposition 5, since we proved that the resulting open book on the plumbing is horizontal. \square

Remark 9. *In fact, the same argument can be generalized to prove that the contact structure compatible with any horizontal open book on a plumbing is horizontal.*

Example 1. Consider the 3-manifold Y_1 obtained by plumbing circle bundles over tori according to the graph in Figure 6. Degree-one vertices have $e_i + d_i = -1$ but the other two vertices have degree equal to three and $e_j + d_j = 0$.

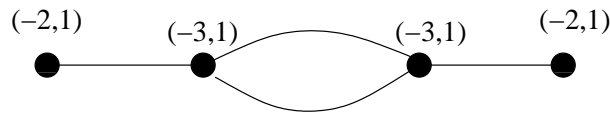
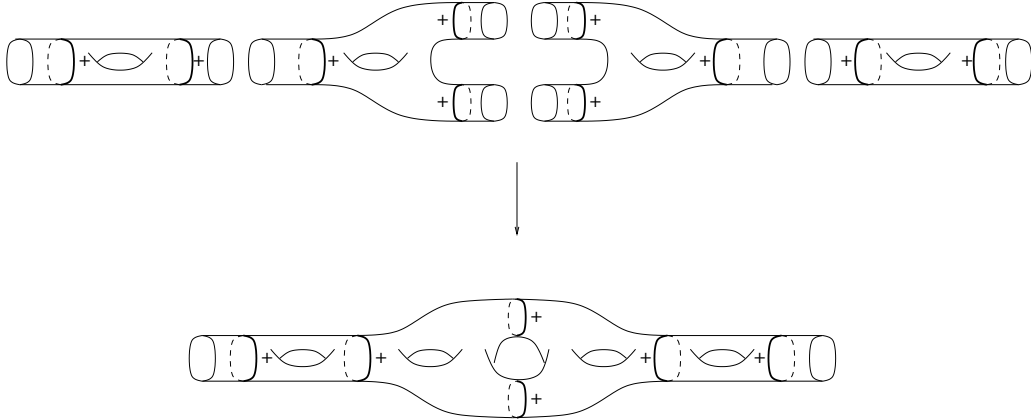

FIGURE 6. The integer weights at each vertex are the Euler number and the genus of the base of the corresponding circle bundle, respectively.

Therefore the horizontal open book \mathfrak{ob}_1 we construct according to the recipe above will have a twice punctured (one puncture for each of the degree-one vertices in the graph) genus 5 surface as a page and the product of 2 right-handed Dehn twists along 2 disjoint separating curves, 2 right-handed Dehn twists along 2 disjoint non-separating curves and one right-handed Dehn twist parallel to each boundary component as its monodromy (see Figure 7). The open book \mathfrak{ob}_1 is an explicit horizontal open book on Y_1 .

FIGURE 7. The open book ob_1

Remark 10. In [Ga], using 4–dimensional symplectic handle attachments, Gay also gives a construction of open books on plumbings of circle bundles. It turns out that the page and the monodromy of the open book we construct on a given plumbing coincides with the one given in [Ga]. This shows that the open book we construct on a plumbing is (abstractly) isomorphic to Gay’s open book, showing that the open book in his construction can be made horizontal for a non-positive plumbing.

Corollary 11. A Seifert fibered 3–manifold Y with an orientable base of genus g and Seifert invariants (see [OS] for conventions)

$$\{g, n; r_1, r_2, \dots, r_k\}$$

admits a horizontal open book if $n + k \leq 0$. If $g = 0$, this open book can be chosen to be planar.

Proof. By [Or], any Seifert fibered 3–manifold Y is isomorphic (as a 3–manifold with S^1 –action) to the boundary of a 4–manifold with S^1 –action obtained by equivariant plumbing of disk bundles according to a weighted star-shaped graph as in Figure 8, where

$$[b_{i1}, b_{i2}, \dots, b_{is_i}] = b_{i1} - \frac{1}{b_{i2} - \frac{1}{\dots - \frac{1}{b_{is_i}}}}$$

is the unique continued fraction expansion of $1/r_i$ with each $b_{ij} \geq 2$. Since each $b_{ij} \geq 2$, every vertex except for the central one satisfies the non-positivity assumption. If the central vertex also satisfies $n + k \leq 0$, then the Seifert fibered 3–manifold admits a horizontal open book. □

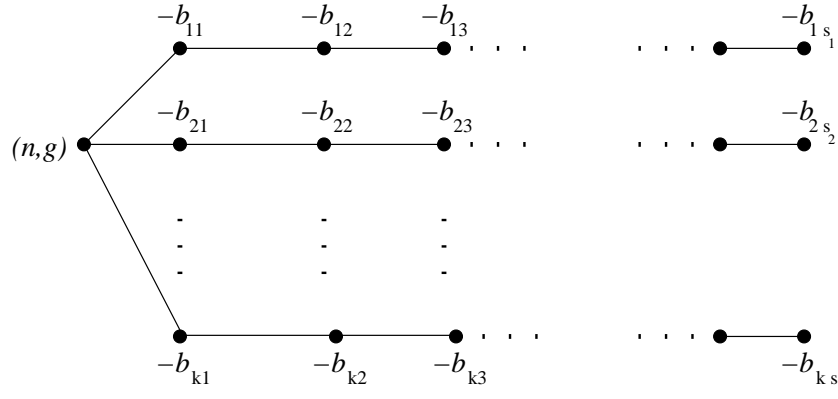

FIGURE 8. The plumbing graph of the Seifert fibered 3–manifold Y with Seifert invariants $\{g, n; r_1, r_2, \dots, r_k\}$. All bundles except the one at the central vertex are over spheres.

4. MILNOR OPEN BOOKS

Let (X, x) be an isolated complex-analytic singularity. Given a local embedding of (X, x) in $(\mathbb{C}^N, 0)$. Then a small sphere $S_\epsilon^{2N-1} \subset \mathbb{C}^N$ centered at the origin intersects X transversely, and the complex hyperplane distribution ξ on $Y = X \cap S_\epsilon^{2N-1}$ induced by the complex structure on X is a contact structure. For sufficiently small radius ϵ the contact manifold (Y, ξ) is independent of the embedding and ϵ up to contactomorphism and this contactomorphism type is called the *contact boundary* of (X, x) . A contact manifold (Y', ξ') is said to be *Milnor fillable* and the germ (X, x) is called a *Milnor filling* of (Y', ξ') if (Y', ξ') is contactomorphic to the contact boundary (Y, ξ) of (X, x) . Even though these definitions are valid in all dimensions, we will focus on surface singularities and their boundaries of real dimension 3. Note that any surface singularity can be normalized without changing the contact boundary and normal surface singularities are isolated.

It is a well-known result of Grauert [Gr] that an oriented 3–manifold has a Milnor fillable contact structure if and only if it can be obtained by plumbing oriented circle bundles over surfaces according to a weighted graph with negative definite intersection matrix. On the other hand, a recent discovery (cf. [CNP]) is that any 3–manifold admits at most one Milnor fillable contact structure, up to contactomorphism. This result is obtained by using Milnor open books.

Definition 12. Given an analytic function $f : (X, x) \rightarrow (\mathbb{C}, 0)$ with an isolated singularity at x , the open book decomposition ob_f of the boundary Y of (X, x) with binding $L = Y \cap f^{-1}(0)$ and projection $\pi = \frac{f}{|f|} : Y \setminus L \rightarrow S^1 \subset \mathbb{C}$ is called the Milnor open book induced by f .

Naturally, one can talk about Milnor open books on any Milnor fillable manifold. Milnor open books have certain features that are used in the proof of the uniqueness result mentioned above: they are all compatible with the natural contact structure on the boundary and they are horizontal when considered on the plumbing description of the Milnor fillable 3–manifold.

Remark 13. *By Remark 9 any Milnor fillable contact structure is horizontal.*

On the other hand, if Y is obtained by plumbing k circle bundles, we obtain a k –tuple $\mathbf{n} = (n_1, \dots, n_k)$ for each horizontal open book of Y , where n_i is the number of distinct fibers in the i^{th} circle bundle which appear in the binding. Each n_i is nonnegative by definition. According to Proposition 4.6 in [CNP], if each n_i is positive and the plumbing graph has a nondegenerate intersection matrix, then \mathbf{n} uniquely determines the horizontal open book up to isomorphism. This proposition can be applied to Milnor fillable 3–manifolds since they are obtained by plumbing circle bundles according to negative definite intersection matrices. Also note that, by Giroux correspondence, isomorphic open books are compatible with contactomorphic contact structures.

As a result, given a 3–manifold Y with a Milnor fillable contact structure ξ , to show that any other Milnor fillable contact structure ξ' on Y is contactomorphic to ξ , it suffices to show the existence of a k –tuple \mathbf{n} of positive integers such that for any Milnor filling (X, x) of (Y, ξ') there is a holomorphic function $f : (X, x) \rightarrow (\mathbb{C}, 0)$ with an isolated singularity at x and a Milnor open book ob_f which generates the k –tuple \mathbf{n} . It turns out that such a k –tuple \mathbf{n} exists, and in fact, every \mathbf{n} that satisfies the following two conditions works (see Theorem 4.1 in [CNP]):

- (1) $n_i \geq d_i + 2g_i$ for each i , where g_i is the genus of the base of the i^{th} circle bundle and d_i is the degree of the i^{th} vertex,
- (2) there exists a k –tuple \mathbf{m} of nonnegative integers such that $\mathbf{I} \cdot \mathbf{m} = -\mathbf{n}$, where \mathbf{I} is the (negative definite) intersection matrix of the weighted plumbing graph, and \mathbf{m} and \mathbf{n} are considered as column vectors.

5. EXPLICIT MILNOR OPEN BOOKS

Let (Y, ξ) be a Milnor fillable contact 3–manifold. Then Y can be obtained by plumbing circle bundles. Let G be the weighted graph (with k vertices and a negative definite intersection matrix \mathbf{I}) of such a plumbing, and d_i and (e_i, g_i) denote the degree and the weight of the i^{th} vertex of G respectively.

Proposition 14. *Suppose that*

$$e_i + 2d_i + 2g_i \leq 0$$

holds for every vertex of G . Then the open book of Y we construct in Section 3 is horizontal and isomorphic to a Milnor open book, for any Milnor filling of Y . Moreover the

monodromy of this horizontal open book is given by a product of right-handed Dehn twists along disjoint curves.

Proof. This open book is horizontal and its monodromy is given by a product of right-handed Dehn twists along disjoint curves simply because the plumbing is non-positive. The entries of the k -tuple \mathbf{n} it generates are $n_i = |e_i + d_i|$. The inequality $e_i + 2d_i + 2g_i \leq 0$ implies that $n_i \geq d_i + 2g_i$, and the system $\mathbf{I} \cdot \mathbf{m} = -\mathbf{n}$ has a solution, namely $\mathbf{m} = (1, \dots, 1)$. Therefore the conditions (1) and (2) in Section 4 are satisfied for the vector \mathbf{n} implying the isomorphism between this horizontal open book and a Milnor open book. \square

Example 2. Consider the 3-manifold Y_2 obtained by plumbing circle bundles over spheres according to the graph in Figure 9.

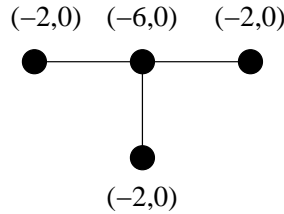

FIGURE 9.

The vertices with degree one have $e_i + d_i = -1$ and the fourth vertex has $e_4 + d_4 = -3$. Note that the intersection matrix

$$\mathbf{I} = \begin{pmatrix} -2 & 0 & 0 & 1 \\ 0 & -2 & 0 & 1 \\ 0 & 0 & -2 & 1 \\ 1 & 1 & 1 & -6 \end{pmatrix}$$

of the plumbing graph is negative definite and hence Y_2 admits a Milnor fillable contact structure. The horizontal open book \mathfrak{ob}_2 we construct for this non-positive plumbing according to the recipe in Section 3 will have a 6-times punctured sphere as a page. The monodromy of \mathfrak{ob}_2 is depicted in Figure 10.

The quadruple generated by this horizontal open book is $\mathbf{n} = (1, 1, 1, 3)$. The system $\mathbf{I} \cdot \mathbf{m} = -\mathbf{n}$ has a solution $\mathbf{m} = (1, 1, 1, 1)$ and as a consequence the horizontal open book \mathfrak{ob}_2 is isomorphic to a Milnor open book for any Milnor filling of Y_2 . In particular, \mathfrak{ob}_2 is compatible with the unique Milnor fillable contact structure on Y_2 . Note that Y_2 is the Seifert fibered manifold with invariants $\{0, -6; 1/2, 1/2, 1/2\}$.

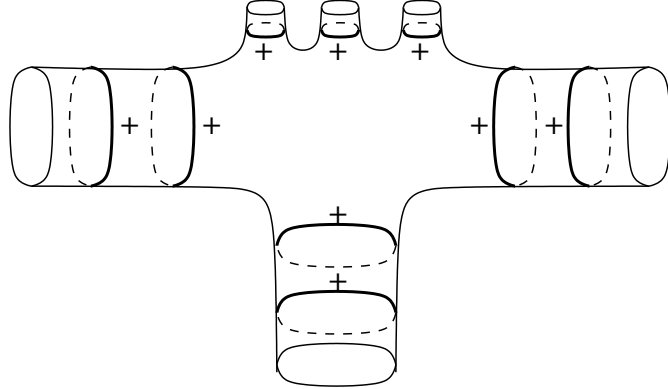
FIGURE 10. The open book σb_2

6. TIGHT PLANAR OPEN BOOKS

In [Et1], Etnyre showed that any overtwisted contact structure on a closed 3–manifold is compatible with a planar open book. He also provided the first obstructions for fillable contact structures to be compatible with planar open books.

Recall that for any given contact 1–form α there is a unique vector field X_α defined by the conditions:

$$\alpha(X_\alpha) = 1 \text{ and } \iota_{X_\alpha} d\alpha = 0.$$

The vector field X_α is called the Reeb vector field of α . Weinstein conjecture says that any Reeb vector field has a closed orbit. For example, every component of the binding of an open book is a closed orbit of the Reeb vector field of any contact 1–form α with $\alpha > 0$ on the binding and $d\alpha > 0$ on the pages of the open book. Recently, the conjecture is proved for every contact structure compatible with a planar open book (cf. [ACH]).

In this section we give examples of horizontal, Stein fillable contact structures compatible with planar open books. As a consequence the Weinstein conjecture holds for these tight contact structures.

Corollary 15. *Let Y be a 3–manifold obtained by a plumbing of circle bundles over spheres according to a tree. Then the open book we construct on this plumbing is planar. If we assume that the plumbing is non-positive then our planar open book is horizontal and compatible with a Stein fillable and horizontal contact structure on Y . Suppose furthermore that the inequality*

$$e_i + 2d_i \leq 0$$

holds for every vertex of the graph. Then our planar horizontal open book is compatible with the unique Milnor fillable contact structure on Y .

Proof. Consider the open book of Y constructed in Section 3. The first claim immediately follows by the fact that the plumbing is according to a tree and the circle bundles involved are over spheres. The second claim follows from the first and Theorem 7. To prove the last claim we just observe that the condition $e_i + 2d_i \leq 0$ trivially implies that the plumbing is negative, i.e. $e_i + d_i < 0$. Hence the plumbing is negative-definite, Y is Milnor fillable and also the open book is horizontal. The open book is isomorphic to a Milnor open book for any Milnor filling of Y by Proposition 14. \square

For example, the open book ob_2 depicted in Figure 10 is a planar horizontal open book compatible with the unique Milnor fillable contact structure on Y_2 . In fact, a surgery diagram of this contact structure is given in Figure 11. We obtained this diagram by comparing our construction with the one described in [Sc]. In Figure 12, we illustrate how to slide a 2-handle to show that Y_2 is diffeomorphic to the 3-manifold in Figure 11.

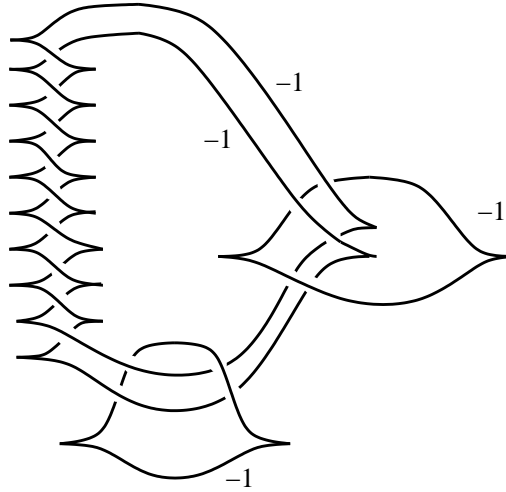

FIGURE 11. A surgery diagram for the unique Milnor fillable contact structure on Y_2 . (The framings are relative to the contact framing.)

7. AN OVERTWISTED EXAMPLE

Example 3. Consider the singularity given by the equation

$$x^2 + y^3 + z^5 = 0$$

in \mathbb{C}^3 . From the minimal resolution we obtain the *dual graph* depicted in Figure 13 and hence the 3-manifold Y_3 obtained by plumbing circle bundles of Euler number -2 over spheres according to this graph is the boundary of the singularity. Note that the intersection

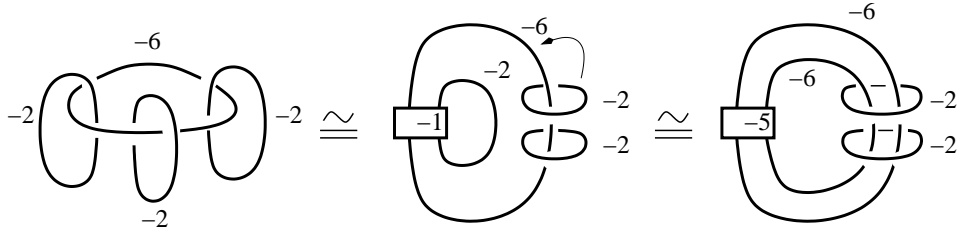

FIGURE 12. Sliding a 2-handle.

matrix of this weighted graph is negative definite and the open book \mathfrak{ob}_3 we construct on Y_3 (which is just is the Poincaré homology sphere $\Sigma(2, 3, 5)$) is depicted in Figure 14.

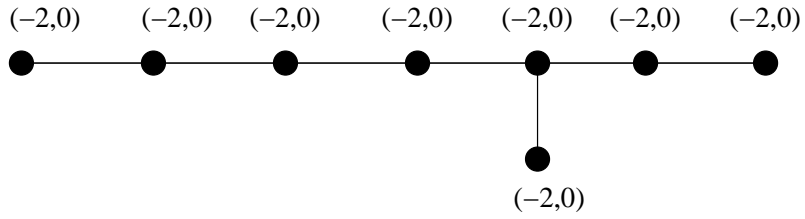

FIGURE 13. Negative definite E_8 -plumbing

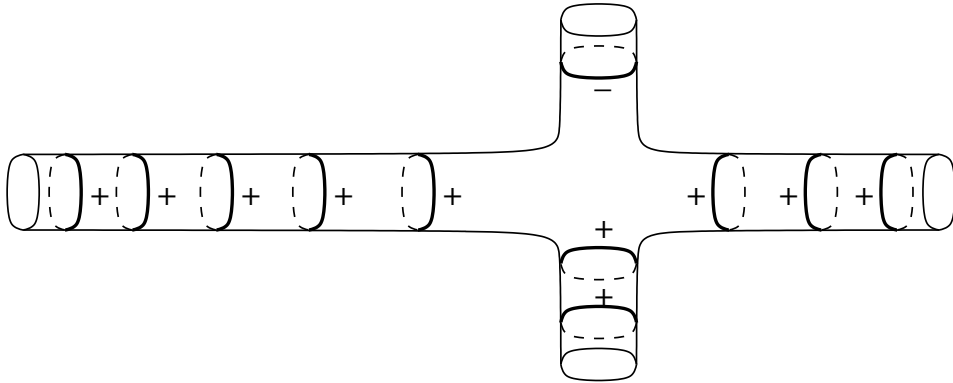

FIGURE 14. \mathfrak{ob}_3 : An overtwisted open book on the Poincaré homology sphere.

We note that the contact structure compatible with \mathfrak{ob}_3 is overtwisted since the Poincaré homology sphere does not admit any planar open book compatible with its unique tight contact structure [Et1]. On the other hand, a contact surgery diagram of the unique tight

contact structure on the Poincaré homology sphere is depicted in Figure 15. This contact structure is clearly the unique Milnor fillable contact structure on $\Sigma(2, 3, 5)$.

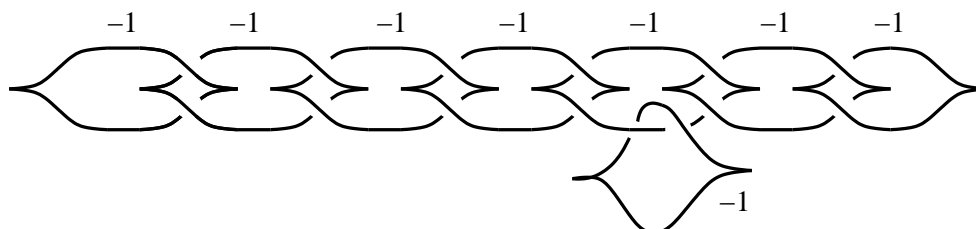

FIGURE 15. A surgery diagram of the unique Milnor fillable contact structure on the Poincaré homology sphere. (The framings are relative to the contact framing.)

REFERENCES

- [ACH] C. Abbas, K. Cieliebak, H. Hofer, *The Weinstein conjecture for planar contact structures in dimension three*; arXiv:math.SG/0409355.
- [Al] J. Alexander, *A lemma on systems of knotted curves*, Proc. Nat. Acad. Sci. USA **9** (1923), 93–95.
- [CNP] C. Caubel, A. Némethi, P. Popescu-Pampu, *Milnor open books and Milnor fillable contact 3-manifolds*; arXiv:math.SG/0409160.
- [EG] Y. Eliashberg and M. Gromov, *Convex symplectic manifolds*, Several complex variables and complex geometry (Santa Cruz, CA, 1989) 135–162.
- [Et1] J. Etnyre, *Planar open book decompositions and contact structures*, IMRN **79** (2004), 4255–4267.
- [Et2] J. Etnyre, *Lectures on open book decompositions and contact structures*, Lecture notes from the Clay Mathematics Institute Summer School on Floer Homology, Gauge Theory, and Low Dimensional Topology at the Alfréd Rényi Institute; arXiv:math.SG/0409402.
- [Ga] D. Gay, *Open books and configurations of symplectic surfaces*, Algebr. Geom. Topol. **3** (2003), 569–586.
- [Gi] E. Giroux, *Géométrie de contact: de la dimension trois vers les dimensions supérieures*, Proceedings of the International Congress of Mathematicians (Beijing 2002), Vol. II, 405–414.
- [Gr] H. Grauert, *Über Modifikationen und exzeptionelle analytische Mengen*, Math. Ann. **146** (1962), 331–368.
- [GS] R. Gompf and A. Stipsicz, *4-manifolds and Kirby calculus*, Grad. Stud. Math., Vol. **20**, AMS, 1999.
- [H] K. Honda, *On the classification of tight contact structures II*, J. Diff. Geom., **55** (2000), 83–143.
- [M] J. Martinet, *Formes de contact sur les variétés de dimension 3*, in: Proc. Liverpool Singularity Sympos. II, Lecture Notes in Math. **209**, Springer, Berlin (1971), 142–163.
- [Or] P. Orlik, *Seifert manifolds*, Lecture Notes in Math., Vol. **291**, Springer, 1972.
- [OS] B. Ozbagci and A. Stipsicz, *Surgery on contact 3-manifolds and Stein surfaces*, Bolyai Soc. Math. Stud., Vol. **13**, Springer, 2004.
- [R] D. Rolfsen, *Knots and links*, Publish or perish, 1976.
- [Sc] S. Schönberger, *Planar open books and symplectic fillings*, Ph.D. Dissertation, University of Pennsylvania, 2005.

DEPARTMENT OF MATHEMATICS, KOÇ UNIVERSITY, ISTANBUL, TURKEY

E-mail address: tetgu@ku.edu.tr and bozbagci@ku.edu.tr

CURRENT: SCHOOL OF MATHEMATICS, GEORGIA INSTITUTE OF TECHNOLOGY, ATLANTA, GEORGIA, USA

E-mail address: bozbagci@math.gatech.edu