

GENUS ONE LEFSCHETZ FIBRATIONS ON DISK COTANGENT BUNDLES OF SURFACES

BURAK OZBAGCI

ABSTRACT. We describe a Lefschetz fibration of genus one on the disk cotangent bundle of any closed orientable surface Σ . As a corollary, we obtain an explicit genus one open book decomposition adapted to the canonical contact structure on the unit cotangent bundle of Σ .

1. INTRODUCTION

Let Σ be a closed, connected and orientable surface. Let $(DT^*\Sigma, \omega_{can})$ denote the disk cotangent bundle of Σ equipped with its canonical symplectic structure $\omega_{can} = d\lambda_{can}$, where λ_{can} is the Liouville one form. Let $(ST^*\Sigma, \xi_{can})$ denote the unit cotangent bundle of Σ equipped with its canonical contact structure ξ_{can} defined as the kernel of the restriction of λ_{can} to $ST^*\Sigma$. It follows that $(DT^*\Sigma, \omega_{can})$ is an exact symplectic filling of its contact boundary $(ST^*\Sigma, \xi_{can})$. In fact, $(DT^*\Sigma, \omega_{can})$ can be upgraded to a Weinstein filling of $(ST^*\Sigma, \xi_{can})$ and hence by Cieliebak and Eliashberg [3], $(DT^*\Sigma, J)$ is a Stein filling of $(ST^*\Sigma, \xi_{can})$, for some complex structure J . Therefore, by the work of Akbulut and the author [2] and also Loi and Piergallini [14], $DT^*\Sigma$ admits a Lefschetz fibration over D^2 whose induced open book on the boundary $ST^*\Sigma$ supports ξ_{can} . In this article, we find an explicit Lefschetz fibration $DT^*\Sigma \rightarrow D^2$ with *minimal fiber genus*, whose induced open book on the boundary $ST^*\Sigma$ supports ξ_{can} , using methods specifically tailored to the cotangent bundle of a surface and very different from those general methods described in [2] and [14].

It is clear by definition that the minimal fiber genus of such a Lefschetz fibration must be greater than equal to the support genus $sg(ST^*\Sigma, \xi_{can})$, which is the minimal page genus of an open book decomposition of $ST^*\Sigma$ adapted to ξ_{can} . Let g denote the genus of the surface Σ at hand. For $g = 0$, there is a Lefschetz fibration $DT^*S^2 \rightarrow D^2$, whose regular fiber is the annulus and whose monodromy is the square of the positive Dehn twist along the core circle. The restriction of this Lefschetz fibration to the boundary gives a *planar* open book decomposition of $ST^*S^2 \cong \mathbb{R}P^3$ adapted to ξ_{can} . For $g \geq 1$, however, the contact 3-manifold $(ST^*\Sigma, \xi_{can})$ is known to be non-planar. By an obstruction to planarity due

to Etnyre [5], $sg(ST^*T^2 \cong T^3, \xi_{can}) \neq 0$. Moreover, Van Horn-Morris [20] constructed an explicit open book adapted to (T^3, ξ_{can}) whose page is a genus one surface with three boundary components. Furthermore, McDuff [16] showed that for any $g > 1$, there is an exact symplectic 4-manifold with two convex boundary components, one of which is $(ST^*\Sigma, \xi_{can})$. By capping off the other boundary component with concave symplectic fillings with arbitrarily large b_2^+ (cf. [6]), we obtain strong symplectic fillings of $(ST^*\Sigma, \xi_{can})$ with arbitrarily large b_2^+ . Therefore, $(ST^*\Sigma, \xi_{can})$ cannot be planar for $g > 1$ either, by the aforementioned obstruction of Etnyre. On the other hand, using Giroux's fundamental work [9] on convex contact structures, Massot [15] showed that for $g > 1$, the contact 3-manifold $(ST^*\Sigma, \xi_{can})$ has an adapted open book decomposition whose page is a genus one surface with $4g + 4$ boundary components—*without explicitly describing its monodromy*. To summarize, we have

$$sg(ST^*\Sigma, \xi_{can}) = \begin{cases} 0 & \text{if } g = 0 \\ 1 & \text{if } g > 0. \end{cases}$$

Therefore, for $g > 0$, any Lefschetz fibration $DT^*\Sigma \rightarrow D^2$ whose induced open book on the boundary $ST^*\Sigma$ supports ξ_{can} must have fiber genus at least one. Here we explicitly construct genus one Lefschetz fibrations $DT^*\Sigma \rightarrow D^2$, using two different methods (due to Johns [11] and Ishikawa [10]), and show that these fibrations are isomorphic. As a corollary, we obtain an explicit genus one open book decomposition adapted to the canonical contact structure ξ_{can} on $ST^*\Sigma$. We would like to point out that there is an orientation error in Ishikawa's paper [10] and the total space of the Lefschetz fibrations he constructs is orientation-preserving diffeomorphic to the disk *cotangent* bundle rather than the disk *tangent* bundle (see Section 4.1, for further details). Note that both methods due to Johns and Ishikawa require the choice of a Morse function $f : \Sigma \rightarrow \mathbb{R}$, to begin with.

The results in this paper greatly improve our earlier work in [17], where we used the method of Johns, to describe a Lefschetz fibration $DT^*\Sigma \rightarrow D^2$ of *genus* g and hence a *genus* g open book decomposition adapted to $(ST^*\Sigma, \xi_{can})$. In that article, we used the standard Morse function on Σ , with a unique index zero critical point. The improvement here comes by the choice of a Morse function on Σ with two index zero, $2g + 2$ index one, and two index two critical points. As a matter of fact, Massot obtains an open book decomposition adapted to $(ST^*\Sigma, \xi_{can})$ by promoting any given self-indexed Morse function on Σ to an ordered ξ_{can} -convex Morse function on $ST^*\Sigma$, and the minimum possible genus for his open book decomposition is achieved by using a non-standard Morse function on Σ whose number of critical points of each index agrees with the one that we mentioned above. Moreover, such a Morse function appears again in our construction of a Lefschetz fibration

$DT^*\Sigma \rightarrow D^2$ of genus one, using Ishikawa’s method. The existence of such a Morse function on Σ is the unifying theme in all three constructions, which explains the fact that in each construction, the page of the open book decomposition is of genus one with precisely $4g + 4$ boundary components. Note that, Massot obtains his open book decomposition by “convexifying” any given Morse function on Σ , whereas Johns and Ishikawa obtains their Lefschetz fibrations by “complexifying” the Morse function at hand.

Although the existence of a genus one open book decomposition adapted to $(ST^*\Sigma, \xi_{can})$ essentially follows from the fundamental work of Giroux [9], we believe that by providing an explicit positive factorization of the monodromy of a genus one open book decomposition adapted to ξ_{can} , we fill a gap in the literature. Moreover, we hope that our work maybe used towards settling Wendl’s conjecture [22, Conjecture 9.23]: *Any exact filling of $(ST^*\Sigma, \xi_{can})$ is Liouville deformation equivalent to $(DT^*\Sigma, \omega_{can})$* . This conjecture is true for $g = 1$ as shown by Wendl [21] and some evidence was obtained recently to verify this conjecture affirmatively by Li, Mak and Yasui [12] and also by Sivek and Van-Horn Morris [19], who showed that any exact filling must, at least topologically, bear some resemblance to $DT^*\Sigma$ for $g \geq 2$.

2. CANONICAL CONTACT STRUCTURE ON THE UNIT COTANGENT BUNDLE OF AN ORIENTABLE SURFACE

Suppose that Σ is any closed, connected, orientable surface. A cooriented contact element of Σ is a pair (p, L) where $p \in \Sigma$ and L is a cooriented line tangent to Σ at p . The space of cooriented contact elements of Σ is the collection of all cooriented contact elements of Σ . There exists a canonical coorientable contact structure ξ_{can} on the space of cooriented contact elements of Σ , which is defined as follows. Let π denote the natural projection of the space of cooriented contact elements of Σ onto Σ . For a point $p \in S$ and a cooriented line L in $T_p S$, let $\xi_{(p,L)}$ denote the cooriented plane described uniquely by the equation $\pi_*(\xi_{(p,L)}) = L \in T_p \Sigma$. The canonical contact structure ξ_{can} on the space of cooriented contact elements of Σ consists of these planes.

If Σ is equipped with an arbitrary Riemannian metric μ , then there is a bundle isomorphism Φ from the tangent bundle $T\Sigma$ to the cotangent bundle $T^*\Sigma$, which is defined fiber-wise

$$\Phi_p : T_p \Sigma \rightarrow T_p^* \Sigma$$

by $v \rightarrow \mu_p(v, -)$, for any $p \in \Sigma$. This induces a bundle metric μ^* on $T^*\Sigma$ by

$$\mu_p^*(u_1, u_2) = \mu_p(\Phi_p^{-1}(u_1), \Phi_p^{-1}(u_2))$$

for any $u_1, u_2 \in T_p^*\Sigma$. Therefore, one can define the unit tangent bundle $ST\Sigma$ and the unit cotangent bundle $ST^*\Sigma$ fiberwise as the collection of unit length vectors and covectors in $T_p\Sigma$ and $T_p^*\Sigma$, respectively.

The space of cooriented contact elements of Σ can be identified with the unit tangent bundle $ST\Sigma$ as well as the unit cotangent bundle $ST^*\Sigma$. The identification with $ST\Sigma$ is given by taking a cooriented contact element (p, L) to the vector $v \in ST_p\Sigma$, which is positively orthonormal to L in $T_p\Sigma$ with respect to μ_p . Similarly, the identification with $ST^*\Sigma$ is given by taking a cooriented contact element (p, L) to the unit covector $\Phi_p(v) = \mu_p(v, -) \in T_p^*\Sigma$. Note that the Liouville 1-form λ_{can} on $T^*\Sigma$ descends to a contact 1-form on $ST^*\Sigma$, denoted again by λ_{can} . The canonical contact structure ξ_{can} on $ST^*\Sigma$ is given by the kernel of λ_{can} under the above identification (see for example [8, page 32]).

The disk tangent bundle $DT\Sigma$ and the disk cotangent bundle $DT^*\Sigma$ are defined fiberwise as the collection of vectors and covectors of length less than or equal to one in $T_p\Sigma$ and $T_p^*\Sigma$, respectively. It follows that $\partial(DT\Sigma) = ST\Sigma$ and $\partial(DT^*\Sigma) = ST^*\Sigma$. By the discussion above, we get an *orientation-reversing* diffeomorphism between $DT^*\Sigma$ and $DT\Sigma$. Moreover, the disk cotangent bundle $DT^*\Sigma$ equipped with its canonical symplectic structure $\omega_{can} = d\lambda_{can}$ is an exact symplectic filling of its contact boundary $(ST^*\Sigma, \xi_{can})$.

3. A GENUS ONE LEFSCHETZ FIBRATION ON THE DISK COTANGENT BUNDLE OF AN ORIENTABLE SURFACE

3.1. Exact symplectic Lefschetz fibrations on cotangent bundles. An exact symplectic structure on a smooth 4-manifold X with codimension 2 corners is an exact symplectic 2-form $\omega = d\lambda$ on X such that the Liouville vector field (which is by definition ω -dual to λ) is transverse to each boundary stratum of codimension 1 and points outwards. Note that λ induces a contact form on each boundary stratum and (W, ω) becomes an exact symplectic filling of its contact boundary $(\partial X, \ker \lambda)$ provided that the corners of W are rounded off (cf. [18, Lemma 7.6]).

Definition 3.1. Suppose that $(X, \omega = d\lambda)$ is an exact symplectic 4-manifold with codimension 2 corners. We say that a smooth map $\pi : X \rightarrow D^2$ is an exact symplectic Lefschetz fibration on (X, ω) if it the following four conditions are satisfied.

(1) There are finitely many critical points q_1, \dots, q_k of the map π , all of which belong to the interior of X . In addition, around each critical point, the smooth map π is modeled on the map $(z_1, z_2) \rightarrow z_1^2 + z_2^2$ in complex local coordinates compatible with the orientations on X and D^2 , respectively.

(2) Each fiber of the map $\pi|_{X \setminus \{q_1, \dots, q_k\}} : X \setminus \{q_1, \dots, q_k\} \rightarrow D^2$ is a symplectic submanifold of (X, ω) .

(3) The boundary ∂X is the union of two smooth strata meeting at a codimension 2 corner. More precisely, $\partial X = \partial_v X \cup \partial_h X$ where

$$\partial_v X = \pi^{-1}(\partial D^2) \text{ and } \partial_h X = \bigcup_{x \in D^2} \partial(\pi^{-1}(x)).$$

(4) We also require that $\pi|_{\partial_v X} : \partial_v X \rightarrow \partial D^2$ is smooth fibration and π is a trivial smooth fibration over D^2 near $\partial_h X$.

The stratum $\partial_v X$ admits a surface fibration over S^1 , while the stratum $\partial_h X$ is a disjoint union of $m > 0$ copies of the solid torus $S^1 \times D^2$, and these strata meet each other at the corner

$$\partial_v X \cap \partial_h X = \partial(\partial_h X) = \prod_{i=1}^m (S^1 \times \partial D^2).$$

We conclude that ∂X , provided that the corners of X are rounded off, acquires an open book decomposition given by $\pi|_{\partial X \setminus B} : \partial X \setminus B \rightarrow \partial D^2$ where $\partial_h X$ is viewed as a tubular neighborhood of the binding

$$B = \prod_{i=1}^m (S^1 \times \{0\}).$$

Moreover, the 1-form λ restricts to a contact form on ∂X whose kernel is a contact structure supported by this open book decomposition.

Remark 3.2. If we suppress the symplectic form ω on X , then a smooth map $\pi : X \rightarrow D^2$ which satisfies only the conditions (1) and (4) in Definition 3.1 is called a Lefschetz fibration on X .

Definition 3.3. For $i = 1, 2$, let $(X_i, \omega_i = d\lambda_i)$ be an exact symplectic 4-manifold with convex boundary. A conformal exact symplectomorphism from (X_1, ω_1) to (X_2, ω_2) is a diffeomorphism $\psi : X_1 \rightarrow X_2$ such that $\psi^* \lambda_2 = C \lambda_1 + dh$ for some smooth function $h : X_1 \rightarrow \mathbb{R}$, and some real number $C > 0$. If $C = 1$, then ψ is called an exact symplectomorphism.

Now, we briefly recall the main result of Johns in [11], which we tailor appropriately to fit in with the context of the present article. Let Σ be a closed, connected, orientable surface of genus g equipped with a Morse function $f : \Sigma \rightarrow \mathbb{R}$ and a Riemannian metric μ such that (f, μ) is Morse-Smale. Based on this data, Johns constructed an exact symplectic Lefschetz fibration $\pi_f : (E, \omega) \rightarrow D^2$ such that there is a conformally exact symplectomorphism

$\phi : (E, \omega) \rightarrow (DT^*\Sigma, \omega_{can})$. Here we assume that the corners of E are rounded off, so that it can be viewed as an exact symplectic 4-manifold with convex boundary.

Remark 3.4. Since any conformal exact symplectomorphism is, in particular, a diffeomorphism by definition, we conclude that E is diffeomorphic to $DT^*\Sigma$, and we view π_f as a Lefschetz fibration on $DT^*\Sigma$. Moreover, since $(E, \omega = d\lambda)$ is a exact symplectic filling of its contact boundary $(\partial E, \ker \lambda)$ and the conformal exact symplectomorphism $\phi : (E, \omega) \rightarrow (DT^*\Sigma, \omega_{can})$ satisfies $\phi^*\omega_{can} = K\omega$ for some constant $K > 0$, the open book decomposition induced by π_f on the boundary $\partial(DT^*\Sigma) = ST^*\Sigma$ supports the canonical contact structure ξ_{can} .

In the following, we apply Johns' method to construct an explicit Lefschetz fibration $DT^*\Sigma \rightarrow D^2$, with the caveat above, where the regular fiber is a surface of genus one with $4g + 4$ boundary components. To illustrate the method of construction, we first give in Section 3.2 a detailed treatment when Σ is a closed, orientable surface of genus one.

3.2. The case of T^2 . The construction of Johns [11] starts with a Morse function $T^2 \rightarrow \mathbb{R}$ or equivalently a handle decomposition of T^2 , which possibly includes twisted 1-handles. Instead of giving an explicit Morse function on T^2 , here we describe a handle decomposition of T^2 given by two 0-handles, four twisted 1-handles, and two 2-handles. The four 1-handles are attached to the 0-handles as shown in Figure 1. The result is an orientable surface of genus one with two boundary components. We obtain T^2 by attaching the 2-handles.

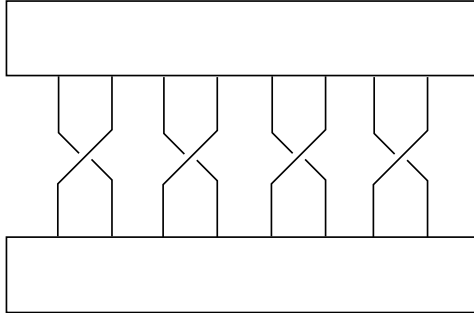

FIGURE 1. The top and bottom rectangular regions are the 0-handles, while each twisted band connecting them is a twisted 1-handle.

Based on this handle decomposition of T^2 , we describe a Lefschetz fibration $DT^*T^2 \rightarrow D^2$ of genus one, using the recipe given explicitly in [11, Section 4.3]. We first describe the regular fiber of the Lefschetz fibration $DT^*T^2 \rightarrow D^2$, as an abstract surface of genus

one with eight boundary components. We start with two disjoint annuli A_1 and A_2 corresponding to the 0-handles of T^2 as depicted in Figure 2, where the horizontal rectangular region labeled by A_i represents the annulus A_i by identifying its left-edge with its right-edge, for $i = 1, 2$. Now, for each twisted 1-handle of T^2 , we attach two 1-handles to the union $A_1 \cup A_2$, which is equivalent to plumbing an annulus. Therefore, we plumb four disjoint annuli B_1, B_2, B_3, B_4 to $A_1 \cup A_2$, where each annulus B_j is represented by the vertical rectangular region labeled by B_j in Figure 2, by identifying its top-edge with its bottom-edge, for $j = 1, 2, 3, 4$. Note that these six annuli are plumbed together in the eight overlapping squares in Figure 2. As a result, we obtain an orientable surface of genus one with eight boundary components, which is the regular fiber of the Lefschetz fibration $DT^*T^2 \rightarrow D^2$.

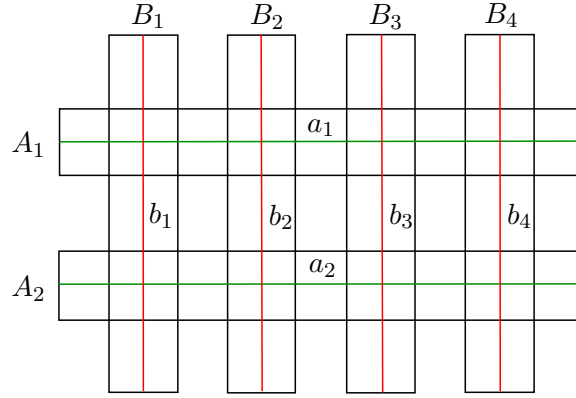
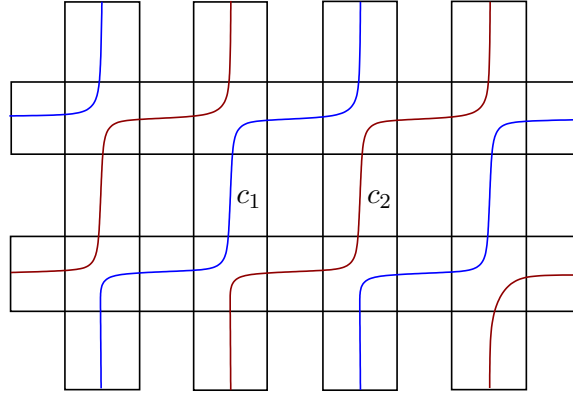

FIGURE 2. The vanishing cycles $a_1, a_2, b_1, b_2, b_3, b_4$.

Next, we describe the vanishing cycles of this Lefschetz fibration. The first two vanishing cycles are the core circles of A_1 and A_2 , which we denote by a_1 and a_2 , respectively. The next four vanishing cycles are the core circles of B_1, B_2, B_3, B_4 , which we denote by b_1, b_2, b_3, b_4 , respectively (see Figure 2). The last two vanishing cycles c_1 and c_2 are obtained by performing *simultaneous surgery* of $a_1 \cup a_2$ and $b_1 \cup b_2 \cup b_3 \cup b_4$ at each point where these curves meet. This means that any time a_i intersects some b_j , the intersection point is resolved by a surgery, where a_i turns to the left as illustrated in Figure 3. By resolving the eight intersection points in Figure 2, we obtain a curve with two components, denoted by c_1 and c_2 as shown in Figure 4.

The monodromy of the Lefschetz fibration $DT^*T^2 \rightarrow D^2$ is given by the composition of positive Dehn twists

$$D(a_1)D(a_2)D(b_1)D(b_2)D(b_3)D(b_4)D(c_1)D(c_2).$$

FIGURE 3. Surgery at a point where a_i meets b_j .FIGURE 4. The last two vanishing cycles c_1 and c_2 .

To summarize, we proved the following result.

Proposition 3.5. *There exists a Lefschetz fibration $DT^*T^2 \cong T^2 \times D^2 \rightarrow D^2$, whose regular fiber is a surface of genus one with eight boundary components. The monodromy of this Lefschetz fibration is given by the composition of positive Dehn twists*

$$D(a_1)D(a_2)D(b_1)D(b_2)D(b_3)D(b_4)D(c_1)D(c_2)$$

where the curves $a_1, a_2, b_1, b_2, b_3, b_4, c_1, c_2$ are depicted in Figures 5 and 6 on a standard genus one surface with eight boundary components.

3.3. General case. The discussion in Section 3.2 can be generalized to the case of an arbitrary closed, connected, orientable surface Σ of genus $g \geq 0$ as follows. There is a handle decomposition of Σ given by two 0-handles, $2g + 2$ twisted 1-handles, and two 2-handles, where we attach the 1-handles to the 0-handles analogous to the $g = 1$ case (see Figure 1). The result is an orientable surface of genus g with two boundary components. By attaching the 2-handles, we obtain Σ .

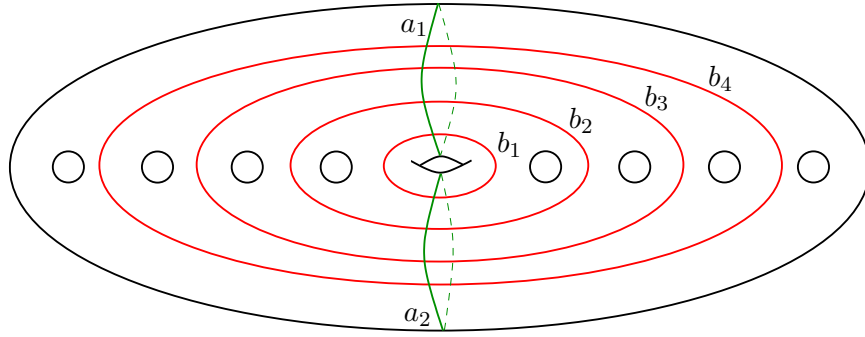
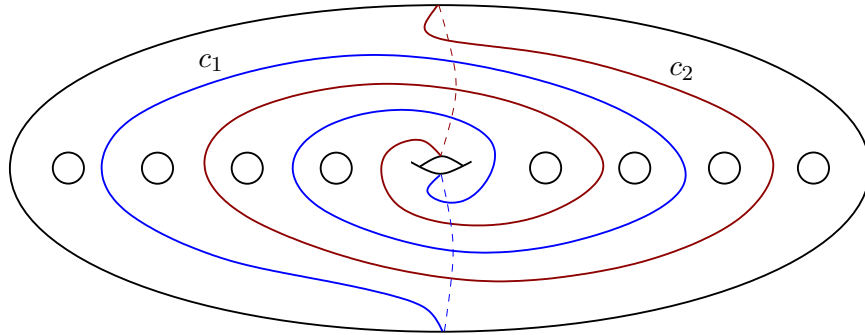
 FIGURE 5. The vanishing cycles $a_1, a_2, b_1, b_2, b_3, b_4$.

 FIGURE 6. The vanishing cycles c_1 and c_2 .

In the following, we describe a Lefschetz fibration $DT^*\Sigma \rightarrow D^2$ of genus one, based on this handle decomposition of Σ . The regular fiber of this Lefschetz fibration is obtained by plumbing $2g + 2$ disjoint annuli B_1, \dots, B_{2g+2} corresponding to the $2g + 2$ twisted 1-handles, to the two disjoint annuli A_1 and A_2 corresponding to the 0-handles, analogous to the $g = 1$ case (see Figure 2). The result is an orientable surface of genus one with $4g + 4$ boundary components.

The vanishing cycles of this Lefschetz fibration are obtained as follows. Let a_i denote the core circle of A_i for $i = 1, 2$ and b_j denote the core circle of B_j for $j = 1, \dots, 2g + 2$. Let c_1 and c_2 denote the two curves on the fiber obtained by simultaneous surgery of $a_1 \cup a_2$ and $b_1 \cup b_2 \cup \dots \cup b_{2g+2}$, at each point where they meet, analogous to the $g = 1$ case (see Figure 4). Therefore, we have the following result.

Theorem 3.6. *For any integer $g \geq 0$, the disk cotangent bundle $DT^*\Sigma$ admits a Lefschetz fibration over D^2 , whose regular fiber is a surface of genus one with $4g + 4$ boundary*

components. The monodromy of this Lefschetz fibration is given by the composition of positive Dehn twists

$$D(a_1)D(a_2)D(b_1)D(b_2) \cdots D(b_{2g+2})D(c_1)D(c_2)$$

where the curves $a_1, a_2, b_1, b_2, \dots, b_{2g+2}, c_1, c_2$ are depicted in Figures 7 and 8 on a standard genus one surface with $4g + 4$ boundary components.

The next corollary immediately follows from Theorem 3.6 coupled with Remark 3.4.

Corollary 3.7. For any integer $g \geq 0$, the unit cotangent bundle $ST^*\Sigma$ admits an open book decomposition adapted to the canonical contact structure ξ_{can} , whose page is a genus one surface with $4g + 4$ boundary components. The monodromy of this open book decomposition is given by the composition of positive Dehn twists

$$D(a_1)D(a_2)D(b_1)D(b_2) \cdots D(b_{2g+2})D(c_1)D(c_2)$$

where the curves $a_1, a_2, b_1, b_2, \dots, b_{2g+2}, c_1, c_2$ are depicted in Figures 7 and 8.

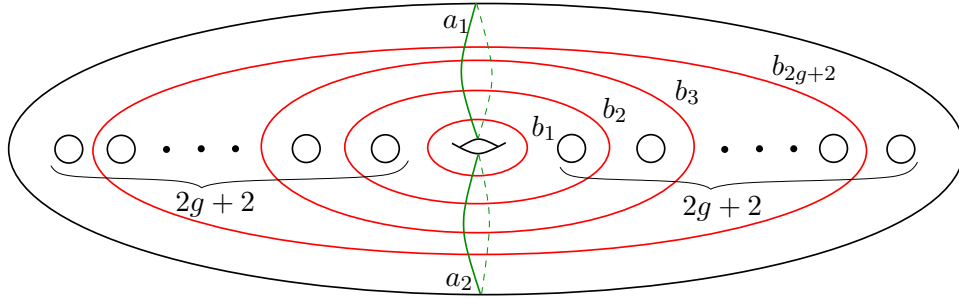

FIGURE 7. The vanishing cycles $a_1, a_2, b_1, b_2, b_3, \dots, b_{2g+2}$.

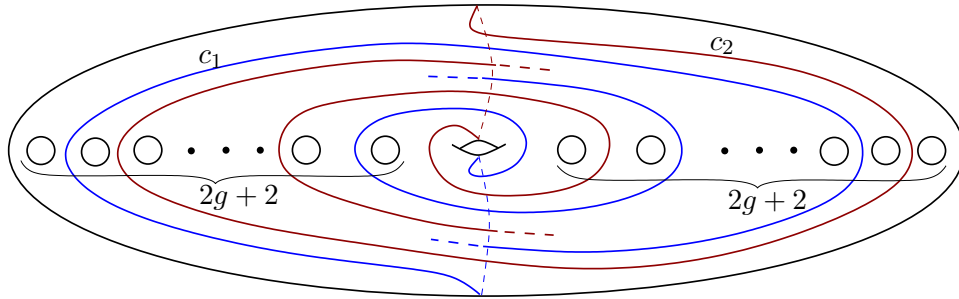

FIGURE 8. The vanishing cycles c_1 and c_2 .

Note that for $g = 0, 1$, the results above are known to be not optimum in the following sense. For $g = 0$, there is a *planar* Lefschetz fibration $DT^*S^2 \rightarrow D^2$, whose regular fiber is the annulus and whose monodromy is the square of the positive Dehn twist along the core circle. The restriction of this Lefschetz fibration to the boundary gives a *planar* open book decomposition of $ST^*S^2 \cong \mathbb{R}P^3$ adapted to ξ_{can} . In other words, the support genus of $(\mathbb{R}P^3, \xi_{can})$ is zero, while its binding number is equal to two (cf. [7]).

As we have already mentioned in the Introduction, the contact 3-manifold $(ST^*\Sigma, \xi_{can})$ is not planar for $g \geq 1$. For $g = 1$, Van Horn-Morris [20] constructed an explicit open book decomposition adapted to $(ST^*T^2 \cong T^3, \xi_{can})$ whose page is a genus one surface with *three* boundary components. Therefore, the support genus of (T^3, ξ_{can}) is one, while its binding number is less than or equal to three. As observed by Massot [15], and confirmed via different methods by our Corollary 3.7, for any $g \geq 1$, the support genus of $(ST^*\Sigma, \xi_{can})$ is one and the binding number is less than or equal to $4g + 4$. Therefore the following question appears naturally:

Question 3.8. *What is the binding number of $(ST^*\Sigma, \xi_{can})$ for $g \geq 1$?*

Note that $DT^*T^2 \cong T^2 \times D^2$ does not admit a planar Lefschetz fibration over D^2 , even if we do not impose any boundary conditions. Suppose, otherwise, that $T^2 \times D^2$ admits a planar Lefschetz fibration over D^2 . Then we would have a planar strongly symplectically fillable contact structure on the boundary $\partial(T^2 \times D^2) \cong T^3$. This gives a contradiction since ξ_{can} is the unique strongly symplectically fillable contact structure on T^3 by Eliashberg [4], and it is non-planar [5].

4. ANOTHER GENUS ONE LEFSCHETZ FIBRATION ON THE DISK COTANGENT BUNDLE OF AN ORIENTABLE SURFACE

4.1. Lefschetz fibrations on disk cotangent bundles. In [10, Proposition 3.1], Ishikawa constructs a Lefschetz fibration on the disk *tangent* bundle of an orientable surface Σ , based on the choice of a Morse function on Σ . His construction is based on Lemma 3.2, which in turn relies on Lemma 2.6 in his paper. We would like to point out that there is an orientation error in Lemma 2.6 of Ishikawa’s paper. His choice of complex charts in Lemma 2.6 is *orientation-reversing* for the tangent bundle rather than orientation-preserving. Therefore, the Lefschetz fibration he constructs in Proposition 3.1 on the disk tangent bundle $DT\Sigma$ is **achiral**, i.e., all Dehn twists are left-handed. By reversing the orientation of the total space we get a Lefschetz fibration on the disk *cotangent* bundle $DT^*\Sigma$. Thus, we conclude that Ishikawa in fact constructs Lefschetz fibrations on $DT^*\Sigma$ rather than $DT\Sigma$.

Remark 4.1. Here is another way to see the error in Ishikawa’s paper [10]. For $\Sigma = S^2$, Ishikawa’s method would give a Lefschetz fibration on the disk tangent bundle of S^2 , which

is the D^2 -bundle over S^2 with Euler number $+2$. This would imply that the D^2 -bundle over S^2 with Euler number $+2$ admits a Stein structure (cf. [2, 14]) which, indeed, contradicts to the adjunction inequality of Lisca and Matić [13] for Stein surfaces.

With this caveat in mind, we briefly describe Ishikawa’s construction of a Lefschetz fibration on $DT^*\Sigma$. To construct his fibration, Ishikawa starts with any *admissible divide* P on Σ . For the purposes of the present paper, a divide $P \subset \Sigma$ is a generic immersion of the disjoint union of finitely many copies of the unit circle. A divide P is called *admissible* if it is connected, each component of $\Sigma \setminus P$ is simply connected and P admits a checkerboard coloring, which means that one can assign black or white color to each component of $\Sigma \setminus P$, such that any two neighboring components are assigned opposite colors.

Based on an admissible divide P on Σ , there is a Morse function $f_P : \Sigma \rightarrow \mathbb{R}$ associated with P , which essentially means that the zero level set of f_P coincides with P , each double point of P corresponds to a critical point of f_P of index one, and each black (resp. white) region of $\Sigma \setminus P$ contains an index two (resp. zero) critical point of f_P . The Morse function f_P , in turn, gives an “almost complexified Morse function” $F_P : T^*\Sigma \rightarrow \mathbb{C}$ which descends to a Lefschetz fibration $\pi_P : DT^*\Sigma \rightarrow D^2$. Moreover, generalizing the work of A’Campo [1], Ishikawa describes how to obtain the regular fiber and the monodromy of the Lefschetz fibration π_P , based only on the divide P .

In the following, by choosing a particular admissible divide P on Σ and applying Ishikawa’s method, we obtain an explicit Lefschetz fibration $DT^*\Sigma \rightarrow D^2$ in Theorem 4.5, with $2g+6$ vanishing cycles, whose regular fiber is a genus one surface with $4g+4$ boundary components. To illustrate the method of construction, we first give in Section 4.2 a detailed treatment when Σ is a closed, orientable surface of genus one.

4.2. The case of T^2 . In this subsection, by choosing a particular admissible divide on the torus T^2 , we construct an explicit Lefschetz fibration $DT^*T^2 \rightarrow D^2$ of genus one. The admissible divide P we have in mind is the union of the four curves P_1, P_2, P_3, P_4 on T^2 intersecting as in Figure 9. The complement $T^2 \setminus P$ has four connected components each of which is a disk. We assign a checkerboard coloring to $T^2 \setminus P$ as follows. The component bounded by the bold curves, facing the reader in Figure 9, is assigned the white color, which in turn, determines the color of the remaining three components of $T^2 \setminus P$, since neighboring components should have opposite colors. Based on this choice of P , there is a Lefschetz fibration $DT^*T^2 \rightarrow D^2$. The fiber of this Lefschetz fibration can be constructed via A’Campo’s method [1, page 15] as follows: We start with a roundabout, as depicted in Figure 10, for each of the four double points of the divide P .

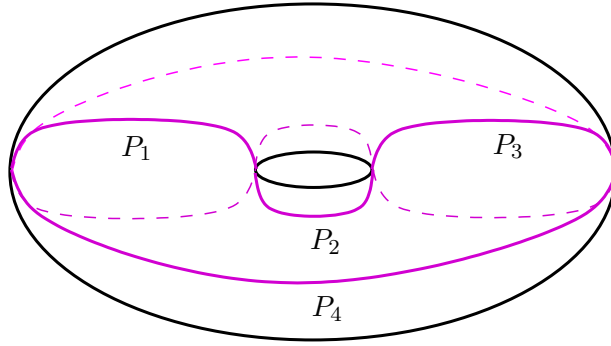

FIGURE 9. The divide $P = P_1 \cup P_2 \cup P_3 \cup P_4$ on T^2 .

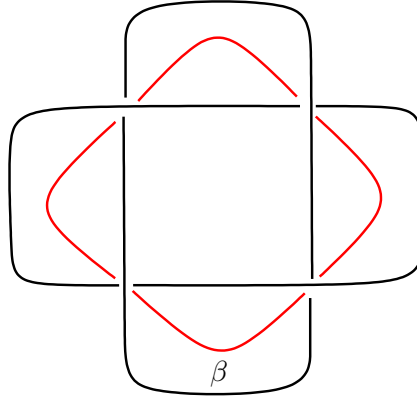

FIGURE 10. The roundabout: an annulus embedded in \mathbb{R}^3 , with its core circle β .

For each edge in P connecting any two double points, we insert a half-twisted band connecting the corresponding roundabouts. As a result, we get a genus one surface with eight boundary components as shown in Figure 11.

The monodromy of this Lefschetz fibration $DT^*T^2 \rightarrow D^2$ is given by the product of eight positive Dehn twists along the curves $\alpha_1, \alpha_2, \beta_1, \beta_2, \beta_3, \beta_4, \gamma_1, \gamma_2$. The curves $\beta_1, \beta_2, \beta_3, \beta_4$ are the core circles of the four roundabouts in Figure 11. The curves α_1 and α_2 are given as the boundary of the two white regions in the checkerboard coloring we fixed above, while the curves γ_1 and γ_2 are given as the boundary of the two black regions. We depicted the curves $\alpha_1, \alpha_2, \gamma_1, \gamma_2$ in Figure 12. We summarize our discussion in Proposition 4.2 below.

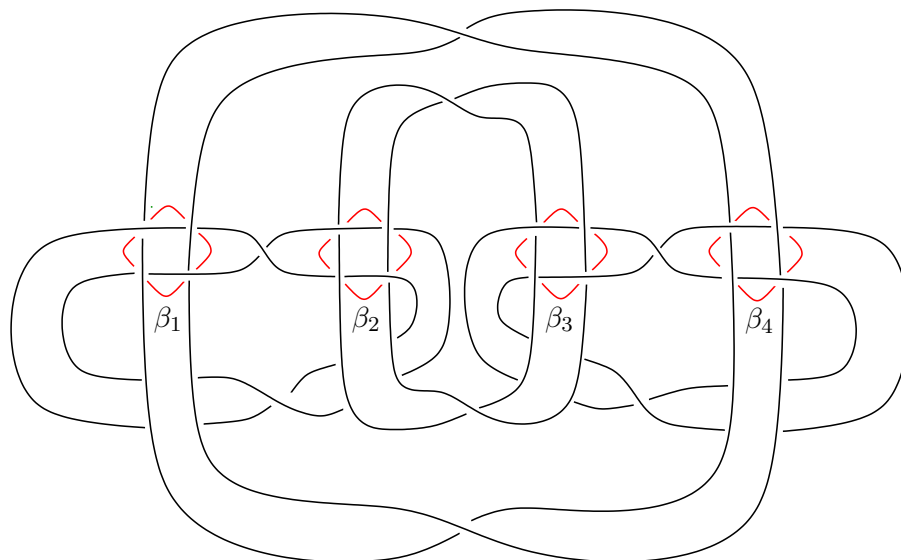

FIGURE 11. The vanishing cycles $\beta_1, \beta_2, \beta_3, \beta_4$.

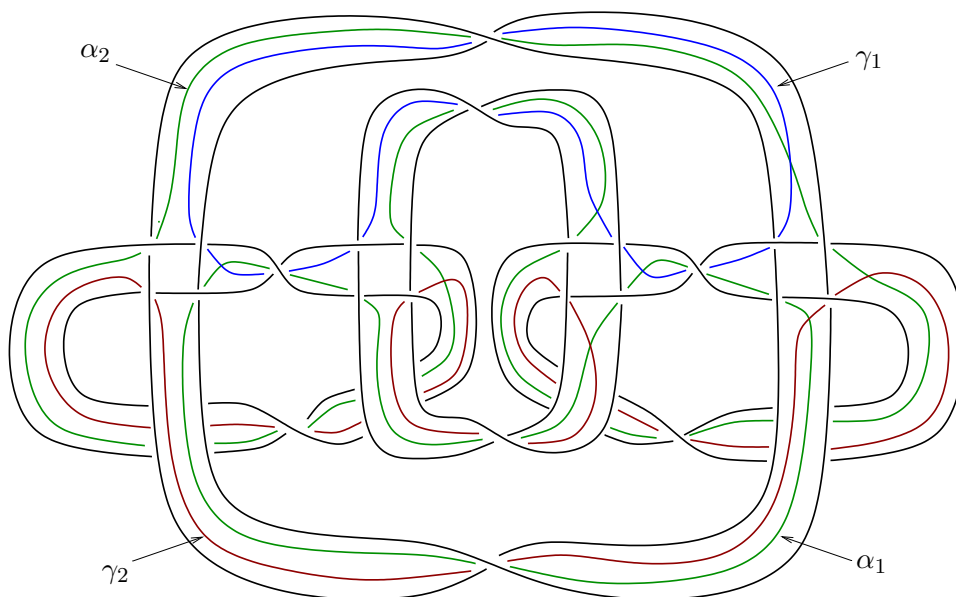

FIGURE 12. The vanishing cycles $\alpha_1, \alpha_2, \gamma_1, \gamma_2$.

Proposition 4.2. *There exists a Lefschetz fibration $DT^*T^2 \cong T^2 \times D^2 \rightarrow D^2$, whose regular fiber is a genus one surface with eight boundary components. The monodromy of this Lefschetz fibration is given by the composition of positive Dehn twists*

$$D(\alpha_1)D(\alpha_2)D(\beta_1)D(\beta_2)D(\beta_3)D(\beta_4)D(\gamma_1)D(\gamma_2)$$

where the curves $\alpha_1, \alpha_2, \beta_1, \beta_2, \beta_3, \beta_4, \gamma_1, \gamma_2$ are depicted in Figures 11 and 12 on a genus one surface with eight boundary components.

Remark 4.3. There is no a priori reason for the existence of a fiberwise diffeomorphism between the Lefschetz fibration $DT^*\Sigma \rightarrow D^2$ described in Theorem 3.6 and the Lefschetz fibration $DT^*\Sigma \rightarrow D^2$ described in Theorem 4.5 that takes the $2g + 6$ vanishing cycles of the former to that of the latter. In Proposition 4.4, we provide such a diffeomorphism for the case $g = 1$. A general statement for any $g \geq 0$ is given in Theorem 4.6 below, whose proof is analogous to the $g = 1$ case.

Proposition 4.4. *The Lefschetz fibration $DT^*T^2 \rightarrow D^2$ described in Proposition 3.5 and the Lefschetz fibration $DT^*T^2 \rightarrow D^2$ described in Proposition 4.2 are isomorphic.*

Proof. Let π_1 denote the Lefschetz fibration $DT^*T^2 \rightarrow D^2$ described in Proposition 3.5 and π_2 denote the Lefschetz fibration $DT^*T^2 \rightarrow D^2$ described in Proposition 4.2. The regular fibers of π_1 and π_2 are clearly diffeomorphic as abstract surfaces. In the following, we establish an explicit diffeomorphism between these fibers which also preserves the corresponding vanishing cycles.

Recall that the fiber (see Figure 2) of π_1 is obtained simply by plumbing the four disjoint annuli $B_1 \cup B_2 \cup B_3 \cup B_4$ onto two disjoint annuli $A_1 \cup A_2$, along the eight overlapping squares. Moreover, the core circle of each annulus is a vanishing cycle. In the following, we show that the fiber (shown in Figure 12) of π_2 is obtained exactly in the same way.

For $i = 1, 2$, a neighborhood of the vanishing cycle α_i on the regular fiber of π_2 , which is shown in Figure 12, is indeed an annulus as we depicted again in Figure 13. Note that to emphasize the neighborhoods of α_1 and α_2 , we erased part of the fiber in Figure 12, which we indicated by the dotted circles in Figure 13. Similarly, for $j = 1, 2, 3, 4$, a neighborhood of the curve β_j on the fiber in Figure 11 is a roundabout. Now we claim that the fiber in Figure 11 (or Figure 12) can be obtained by plumbing the four disjoint roundabouts, each one is a neighborhood of β_j , onto the disjoint union of the neighborhoods of α_1 and α_2 depicted in Figure 13. To prove our claim, we illustrate in Figure 14 the result of plumbing a roundabout onto the disjoint neighborhoods of α_1 and α_2 inside a dotted circle.

Note that inside each one of the four dotted circles in Figure 13, there are two disjoint “twisted squares”, and each plumbing takes place inside one of these circles. Therefore, to establish a diffeomorphism between the regular fiber of π_2 and the regular the fiber of π_1 ,

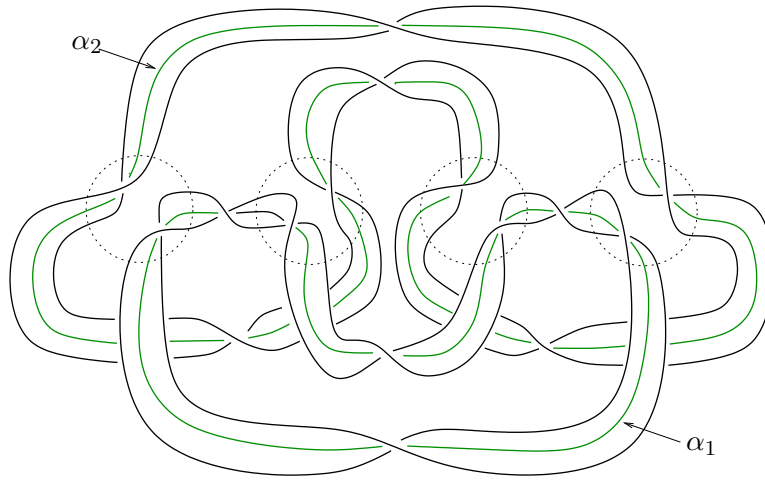

FIGURE 13. The neighborhoods of the vanishing cycles α_1 and α_2 .

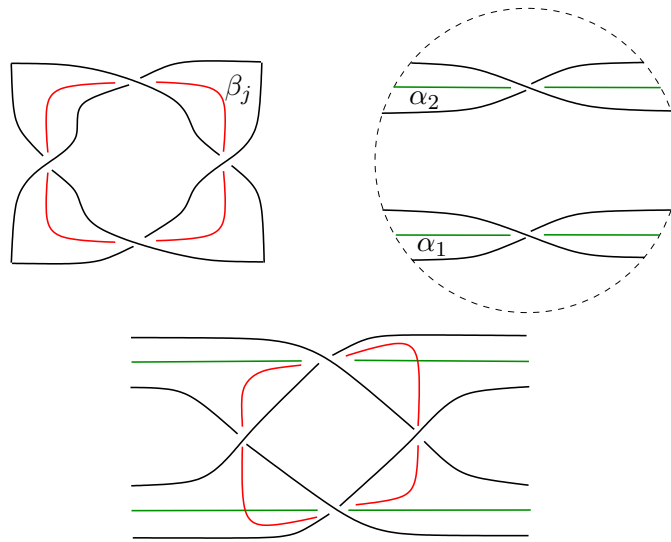

FIGURE 14. Plumbing (bottom) the roundabout (top left) onto the annuli neighborhoods of α_1 and α_2 (top right).

we identify the neighborhood of α_i with the annulus A_i , which is a neighborhood of a_i and the neighborhood of β_j with the annulus B_j , which a neighborhood of b_j . Our discussion

so far shows that the regular fiber of π_2 is diffeomorphic to the regular fiber of π_1 by a diffeomorphism sending α_i to a_i for $i = 1, 2$ and β_j to b_j for $j = 1, 2, 3, 4$.

Finally, recall that the last vanishing cycles c_1 and c_2 of π_1 are obtained by simultaneous surgery of $a_1 \cup a_2$ and $b_1 \cup b_2 \cup b_3 \cup b_4$, at each point where they meet. We just observe that γ_1 and γ_2 are also obtained by simultaneous surgery of $\alpha_1 \cup \alpha_2$ and $\beta_1 \cup \beta_2 \cup \beta_3 \cup \beta_4$, at each point where they meet. We conclude that the diffeomorphism above takes γ_i to c_i as well for $i = 1, 2$. Therefore, there is an isomorphism between the two genus one Lefschetz fibrations $\pi_2 : DT^*T^2 \rightarrow D^2$ and $\pi_1 : DT^*T^2 \rightarrow D^2$. \square

4.3. General case. The discussion in Section 4.2 can be generalized to the case of an arbitrary closed, connected, orientable surface Σ of genus $g \geq 0$ as follows. We start with the admissible divide P on Σ given in Figure 15.

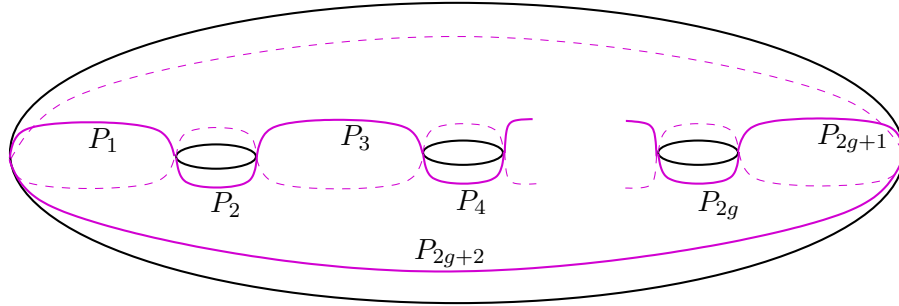

FIGURE 15. The divide $P = P_1 \cup P_2 \cup \dots \cup P_{2g+2}$ on Σ .

Just as in the case of genus one, $\Sigma \setminus P$ has four connected components, each of which is a disk and $\Sigma \setminus P$ admits a checkerboard coloring. Based on this choice of P , there is a Lefschetz fibration $DT^*\Sigma \rightarrow D^2$. The fiber of this Lefschetz fibration can be constructed as described in Section 4.2: We start with a roundabout for each double point of the divide P , and for each edge in P connecting any two double points, we insert a half-twisted band connecting the corresponding roundabouts. As a result, we get a genus one surface with $4g + 4$ boundary components, as shown in Figure 16.

Moreover, the monodromy of this Lefschetz fibration $DT^*\Sigma \rightarrow D^2$ is given by the product of $2g + 6$ positive Dehn twists along the curves $\alpha_1, \alpha_2, \beta_1, \beta_2, \dots, \beta_{2g+2}, \gamma_1, \gamma_2$. The curves $\beta_1, \beta_2, \dots, \beta_{2g+1}, \beta_{2g+2}$ are the core circles of the roundabouts in Figure 16. The curves α_1 and α_2 are given as the boundary of the two white regions in the checkerboard coloring we fixed above, while the curves γ_1 and γ_2 are given as the boundary of the two black regions. We depicted the curves $\alpha_1, \alpha_2, \gamma_1, \gamma_2$ in Figure 17.

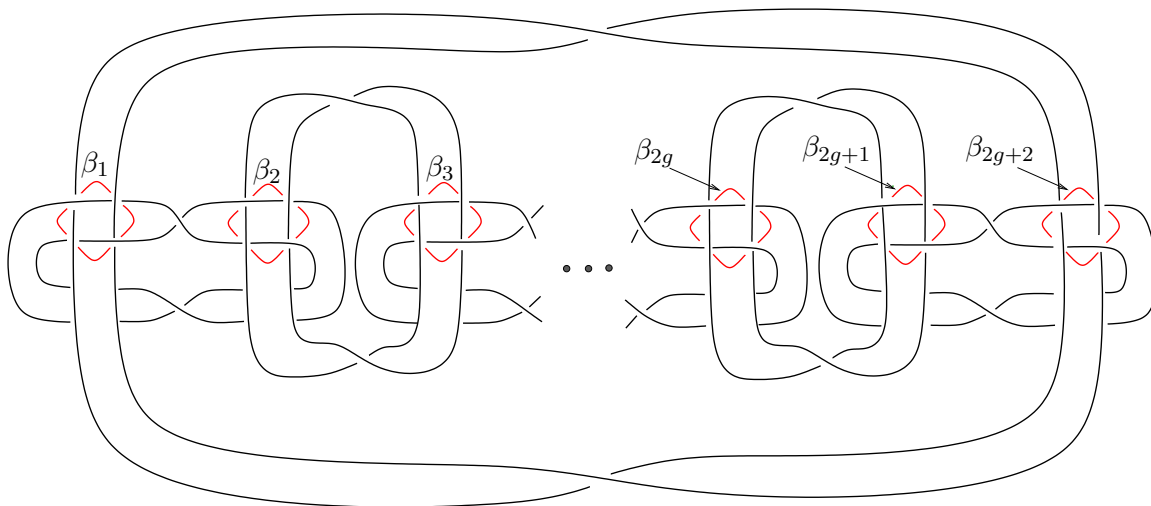

FIGURE 16. The vanishing cycles $\beta_1, \beta_2, \dots, \beta_{2g+2}$.

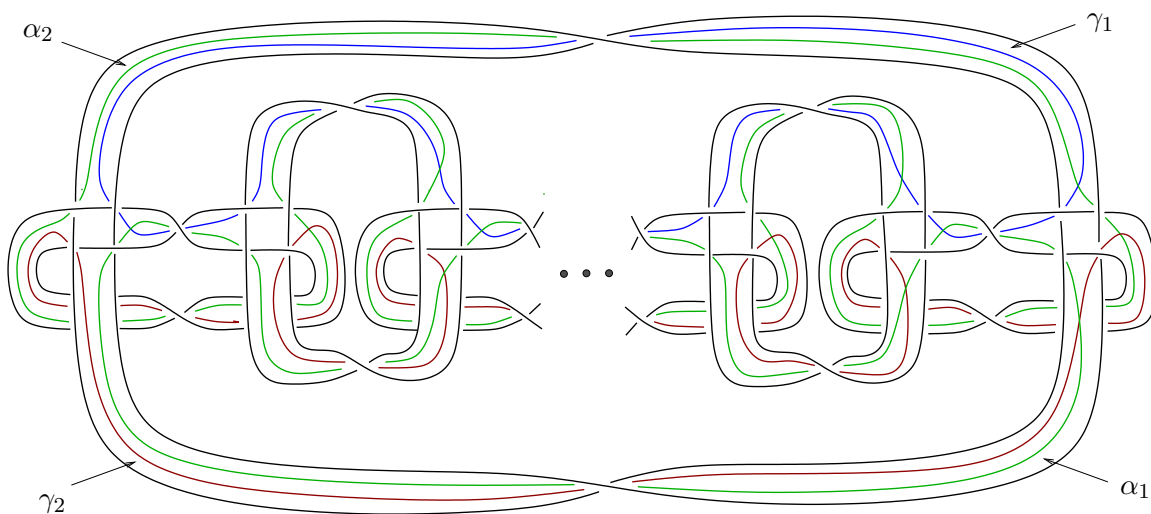

FIGURE 17. The vanishing cycles $\alpha_1, \alpha_2, \gamma_1, \gamma_2$.

The proofs of Theorem 4.5 and Theorem 4.6 are completely analogous to the proofs of Proposition 4.2 and Proposition 4.4, respectively. One crucial observation is that γ_1 and γ_2 are obtained as a result of the simultaneous surgery of $\alpha_1 \cup \alpha_2$ and $\beta_1 \cup \beta_2 \cup \dots \cup \beta_{2g+2}$, at each point where they meet. The reader can verify this directly for the curves depicted in Figures 16 and 17. This fact can also be verified as follows: The α curves are given as

the boundaries of the two zero handles on Σ . The β curves are then formed from the union of the cores of the one handles joined together in the zero handles. The result of surgery between the α and β curves yields a curve isotopic to the boundary of the union of the 0-handles and 1-handles, in other words the attaching circles for the 2-handles. This also explains how the constructions of Ishikawa and Johns relate to the Morse function on Σ in the same way (see [11, page 69]).

Theorem 4.5. *For any integer $g \geq 0$, the disk cotangent bundle $DT^*\Sigma$ admits a Lefschetz fibration over D^2 , whose regular fiber is a genus one surface with $4g + 4$ boundary components. The monodromy of this Lefschetz fibration is given by the composition of positive Dehn twists*

$$D(\alpha_1)D(\alpha_2)D(\beta_1)D(\beta_2) \cdots D(\beta_{2g+2})D(\gamma_1)D(\gamma_2)$$

where the curves $\beta_1, \beta_2, \dots, \beta_{2g+1}, \beta_{2g+2}$ are shown in Figure 16 and $\alpha_1, \alpha_2, \gamma_1, \gamma_2$ are shown in Figure 17.

Theorem 4.6. *For any integer $g \geq 0$, the Lefschetz fibration $DT^*\Sigma \rightarrow D^2$ described in Theorem 3.6 and the Lefschetz fibration $DT^*\Sigma \rightarrow D^2$ described in Theorem 4.5 are isomorphic.*

The next result immediately follows from Theorem 4.6 and Corollary 3.7.

Corollary 4.7. *For any integer $g \geq 0$, the open book decomposition on $ST^*\Sigma$ induced by the Lefschetz fibration $DT^*\Sigma \rightarrow D^2$ described in Theorem 3.6 is isomorphic to the open book decomposition on $ST^*\Sigma$ induced by the Lefschetz fibration $DT^*\Sigma \rightarrow D^2$ described in Theorem 4.5. Therefore, the open book decomposition on $ST^*\Sigma$ induced by the Lefschetz fibration $DT^*\Sigma \rightarrow D^2$ described in Theorem 4.5 supports ξ_{can} as well.*

Finally, we would like to list some questions that arise from the discussion in this paper.

1) Ishikawa does not give any information about the contact structures on $ST^*\Sigma$ adapted to the open book decompositions which are filled by the various Lefschetz fibrations he constructs on $DT^*\Sigma$, depending on different possible choices of an admissible divide on Σ . Our Corollary 4.7 shows that for a certain admissible divide on Σ , Ishikawa's open book decomposition on $ST^*\Sigma$ supports the canonical contact structure ξ_{can} . Is it true that any open book decomposition on $ST^*\Sigma$ given by Ishikawa's construction supports ξ_{can} ?

2) Is the Lefschetz fibration on $DT^*\Sigma$ of Johns (which uses the standard Morse function on the surface) an explicit stabilization of the Lefschetz fibration in this paper? Is there a calculus relating stabilizations and handle slides of Morse functions on Σ with stabilizations and Hurwitz moves on Lefschetz fibrations on $DT^*\Sigma$?

- 3) Is it true that the Lefschetz fibration that Johns constructs on $DT^*\Sigma$ is isomorphic to that Ishikawa constructs for all Morse functions on Σ , not just the specific Morse function that gives the minimal genus Lefschetz fibration?
- 4) Is the number of boundary components in this article minimal amongst all genus one Lefschetz fibrations built from the constructions of Johns/Ishikawa varying over different Morse functions on the surface?

REFERENCES

- [1] N. A'Campo, *Real deformations and complex topology of plane curve singularities*. Ann. Fac. Sci. Toulouse Math. (6) 8 (1999), no. 1, 5-23.
- [2] S. Akbulut and B. Ozbagci, *Lefschetz fibrations on compact Stein surfaces*, Geom. Topol. **5** (2001), 319–334.
- [3] K. Cieliebak and Y. Eliashberg, *From Stein to Weinstein and back. Symplectic geometry of affine complex manifolds*. American Mathematical Society Colloquium Publications, 59. American Mathematical Society, Providence, RI, 2012.
- [4] Y. Eliashberg, *Unique holomorphically fillable contact structure on the 3-torus*. Internat. Math. Res. Notices 1996, no. 2, 77-82.
- [5] J. B. Etnyre, *Planar open book decompositions and contact structures*. Int. Math. Res. Not. 2004, no. 79, 4255–4267.
- [6] J. B. Etnyre, and K. Honda, *On symplectic cobordisms*. Math. Ann. 323 (2002), no. 1, 31–39.
- [7] J. B. Etnyre and B. Ozbagci, *Invariants of contact structures from open books*. Trans. Amer. Math. Soc. 360 (2008), no. 6, 3133-3151.
- [8] H. Geiges, *An introduction to contact topology*. Cambridge Studies in Advanced Mathematics, 109. Cambridge University Press, Cambridge, 2008.
- [9] E. Giroux, *Convexit  en topologie de contact*. (French) [Convexity in contact topology] Comment. Math. Helv. 66 (1991), no. 4, 637–677.
- [10] M. Ishikawa, *Tangent circle bundles admit positive open book decompositions along arbitrary links*. Topology 43 (2004), no. 1, 215–232.
- [11] J. Johns, *Lefschetz fibrations on cotangent bundles of two-manifolds*. Proceedings of the Gokova Geometry-Topology Conference 2011, 53-84, Int. Press, Somerville, MA, 2012.
- [12] T. J. Li, C. Y. Mak, and K. Yasui, *Calabi-Yau caps, uniruled caps and symplectic fillings*. Proc. Lond. Math. Soc. (3) 114 (2017), no. 1, 159–187.
- [13] P. Lisca and G. Mati c, *Tight contact structures and Seiberg-Witten invariants*. Invent. Math. 129 (1997), no. 3, 509–525.
- [14] A. Loi and R. Piergallini, *Compact Stein surfaces with boundary as branched covers of B^4* , Invent. Math. 143 (2001), 325–348.
- [15] P. Massot, *Two remarks on the support genus question*.
<https://www.math.u-psud.fr/~pmassot/files/exposition/genus.pdf>
- [16] D. McDuff, *Symplectic manifolds with contact type boundaries*. Invent. Math. 103 (1991), no. 3, 651–671.
- [17] T. Oba and B. Ozbagci, *Canonical contact unit cotangent bundle*, Adv. Geom. 18 (2018), no. 4, 405–424.

- [18] P. Seidel, *Fukaya categories and Picard-Lefschetz theory*. Zurich Lectures in Advanced Mathematics. European Mathematical Society (EMS), Zürich, 2008.
- [19] S. Sivek and J. Van Horn-Morris, *Fillings of unit cotangent bundles*. Math. Ann. 368 (2017), no. 3-4, 1063–1080.
- [20] J. Van Horn-Morris, *Constructions of open book decompositions*. Ph.D Dissertation, UT Austin, 2007.
- [21] C. Wendl, *Strongly fillable contact manifolds and J -holomorphic foliations*. Duke Math. J. 151 (2010), no. 3, 337-384.
- [22] C. Wendl, *Holomorphic Curves in Low Dimensions. From symplectic ruled surfaces to planar contact manifolds*. Lecture Notes in Mathematics, 2216. Springer, Cham, 2018.

DEPARTMENT OF MATHEMATICS, KOÇ UNIVERSITY, ISTANBUL, TURKEY

E-mail address: bozbagci@ku.edu.tr